

Magnetically Coupled Rodless Cylinder Basic Type

New

Ø 6, Ø 10, Ø 15, Ø 20, Ø 25, Ø 32, Ø 40, Ø 50, Ø 63

RoHS

Lightweight

The product weight has been reduced through re-designing of the body and head cover shapes and employment of magnetic coupling.

Weight

16 % reduction

1.35 kg → 1.13 kg

Compared with the existing CY3B series model,
Ø 32, 100 mm stroke



Improved lubrication

A **Lube-retainer** is installed to support lubrication retention on the piston and to ensure a lubrication film. (Bore size: Ø 15 to Ø 63)

Stable operation

Lengthening of the **wear ring** on the body side by, 30 % at maximum, helps to achieve smooth movement.

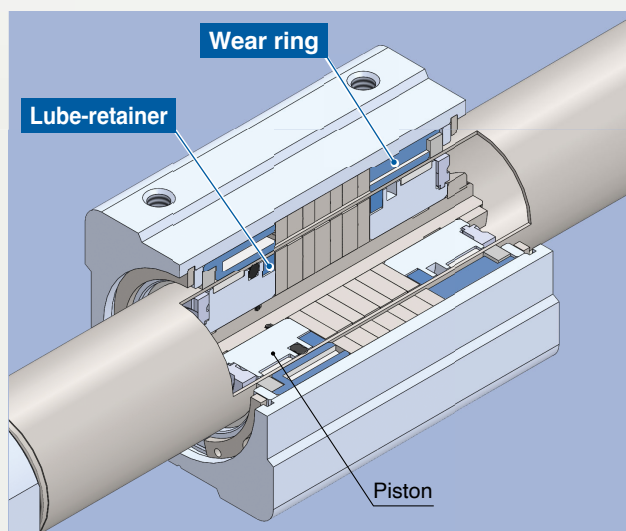

■ The specifications, magnet holding force, and mounting dimensions are the same as those of the existing CY3B series model.

CY3B Series



CAT.EUS20-277A-UK

Magnetically Coupled Rodless Cylinder/ Basic Type *CY3B Series*

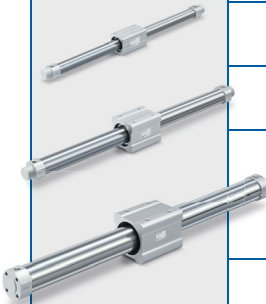
Series	Bore size	Standard stroke [mm]														Piston speed	Cushion	Mounting orientation	Magnet holding force			
		50	100	150	200	250	300	350	400	450	500	600	700	800	900					1000		
	6	●	●	●	●														50 to 500 mm/s	Rubber bumper	Horizontal Inclined Vertical	19.6 N
	10	●	●	●	●	●	●															53.9 N
	15	●	●	●	●	●	●	●	●	●	●											137 N
	20	●	●	●	●	●	●	●	●	●	●	●	●	●	●							231 N
	25	●	●	●	●	●	●	●	●	●	●	●	●	●	●	●	●	●				363 N
	32	●	●	●	●	●	●	●	●	●	●	●	●	●	●	●	●	●				588 N
	40	●	●	●	●	●	●	●	●	●	●	●	●	●	●	●	●	●				922 N
	50	●	●	●	●	●	●	●	●	●	●	●	●	●	●	●	●	●				1471 N
63	●	●	●	●	●	●	●	●	●	●	●	●	●	●	●	●	●	2256 N				



CONTENTS

Model Selection	p. 2
How to Order	p. 6
Specifications	p. 6
Dimensions	p. 8
Specific Product Precautions	p. 9



Related Products

Deceleration Controller DAS Series

[Click here for details](#)

2-speed control reduces cycle time
Allows for the impact relaxation of the stroke end

Allows for the 2-speed control of cylinders

The deceleration position (cushion timing) and **2nd speed (cushion intensity)** can be adjusted.

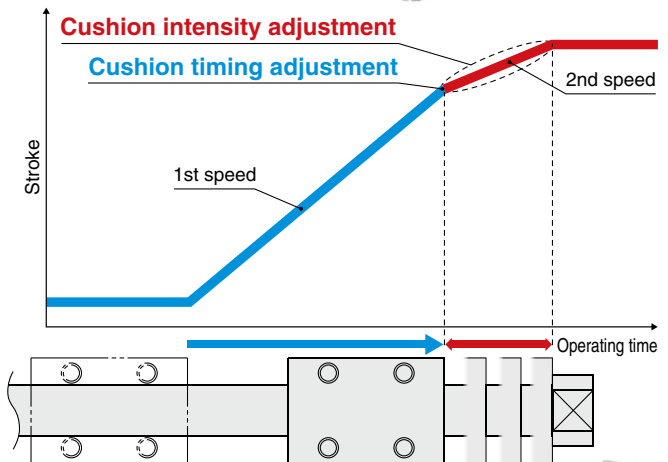

Piping Example

For double-end

Deceleration Controller

L side Deceleration position adjustment
 L side 2nd speed adjustment
 R side Deceleration position adjustment
 R side 2nd speed adjustment

Valve

Air for adjusting the deceleration force position is supplied by drive air

Deceleration position adjustment (Light blue) (Timing knob)
 2nd speed adjustment (Gray) (2nd speed knob)

For single-end

Deceleration Controller

L side Deceleration position adjustment
 L side 2nd speed adjustment

Valve

Air for adjusting the deceleration force position is supplied by drive air

Deceleration position adjustment (Light blue) (Timing knob)
 2nd speed adjustment (Gray) (2nd speed knob)

Variations

Mounting	Body size	Applicable tubing O.D.										Bore size
		Metric size					Inch size					
		4	6	8	10	12	5/32"	1/4"	5/16"	3/8"	1/2"	
	5	•	•	•			•	•	•			Ø 10 to Ø 40
	7			•	•	•			•	•	•	Up to Ø 100

CY3B Series Model Selection

E: Kinetic energy of load [J]

$$E = \frac{(W + W_b)}{2} \times \left(\frac{V}{1000}\right)^2$$

Es: Allowable kinetic energy for intermediate stop using an air pressure circuit [J]

Fn: Allowable driving force [N]

Mb: Max. allowable moment when a connection bracket, etc., is carried directly [N·m]

Ps: Operating pressure limit for intermediate stop using an external stopper, etc. [MPa]

Pv: Max. operating pressure for vertical operation [MPa]

Wbmax: Max. load mass when loaded directly on the body [kg]

Wv: Allowable load mass for vertical operation [kg]

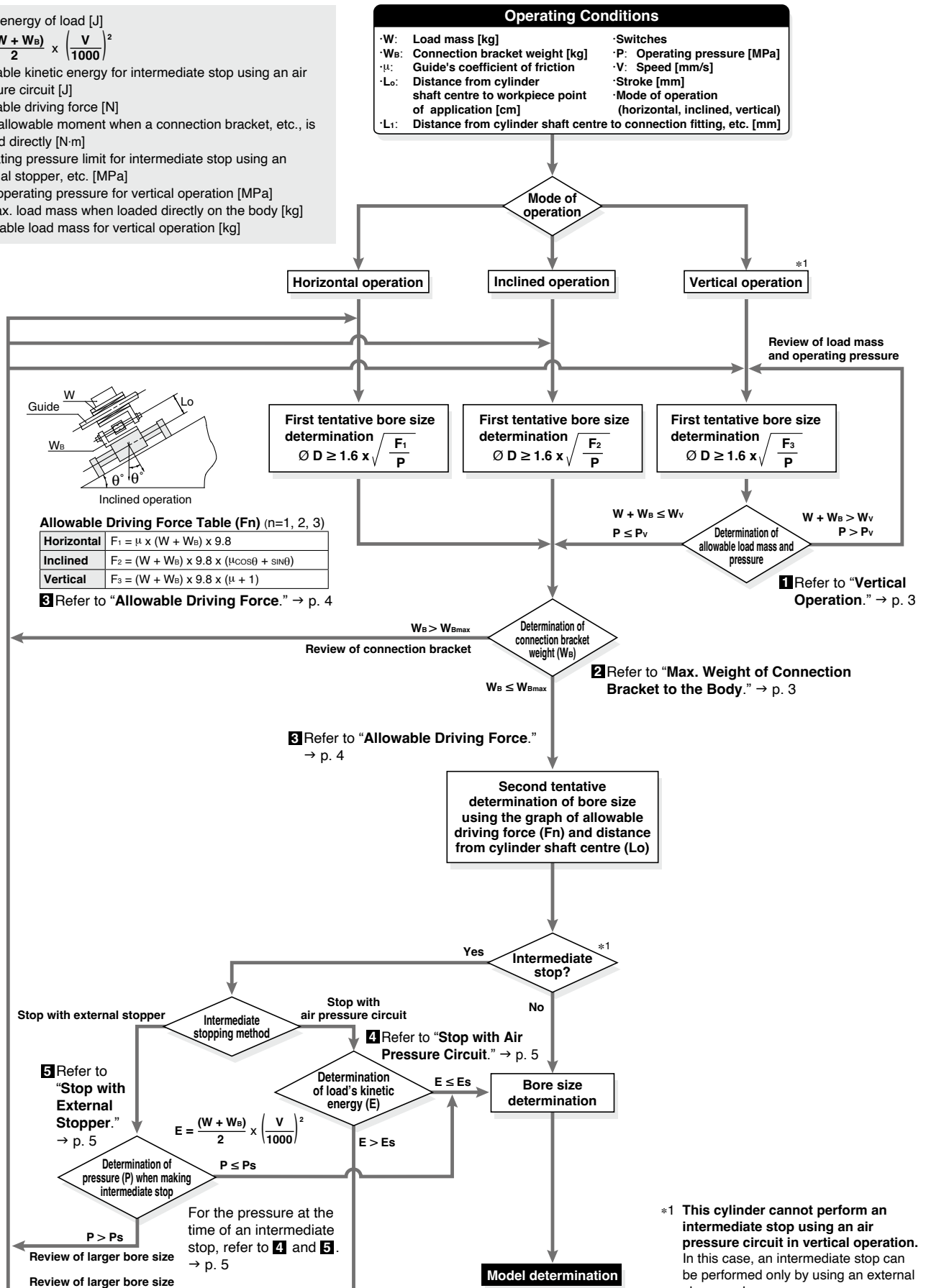

^{*1} This cylinder cannot perform an intermediate stop using an air pressure circuit in vertical operation. In this case, an intermediate stop can be performed only by using an external stopper, etc.

CY3B Series

1 Vertical Operation

It is recommended that the load is guided by a ball type bearing (linear guide, etc.). If a slide bearing is used, sliding resistance increases due to the load mass and moment, which may cause malfunctions.

When the cylinder is mounted vertically or on an angle, be sure to use an external stopper, etc., for positioning.

In addition, as the slider may move downward toward the stroke end due to its self-weight or the mass of the workpiece, use an external stopper, etc., for positioning if accurate positioning is required.

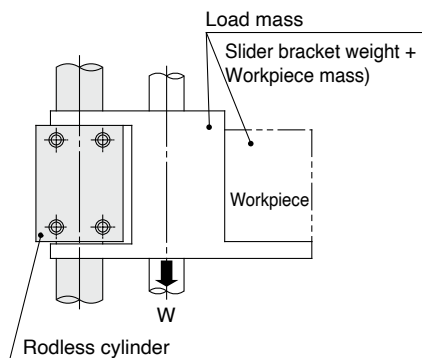

Bore size [mm]	Model	Allowable load mass (Wv) [kg]	Max. operating pressure (Pv) [MPa]
6	CY3B6	1.0	0.55
10	CY3B10	2.7	0.55
15	CY3B15	7.0	0.65
20	CY3B20	11.0	0.65
25	CY3B25	18.5	0.65
32	CY3B32	30.0	0.65
40	CY3B40	47.0	0.65
50	CY3B50	75.0	0.65
63	CY3B63	115.0	0.65

* Use caution, as there is a danger of breaking the magnetic coupling if operated above the max. operating pressure.

Cylinder Self-Weight Deflection

When the cylinder is mounted horizontally, deflection appears due to its self-weight as shown in the data, and the longer the stroke is, the greater the amount of variation in the shaft centre. Therefore, a connection method should be considered which can assimilate this deflection.

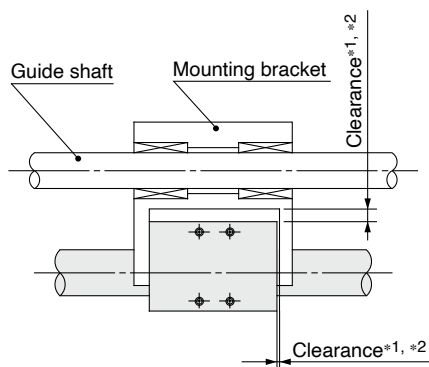

*1 According to the self-weight deflection in the figure on the right, provide clearance so that the cylinder does not touch the mounting surface or the load, etc., and is able to operate smoothly within the min. operating pressure range for a full stroke. For more information, refer to the Operation Manual.

*2 The amount of deflection differs from the CY1B. Adjust the clearance value by referring to the self-weight deflection as shown in the table on the right.

When the CY1B is replaced with the CY3B, install a cylinder after confirming a full stroke and clearance are allowed.

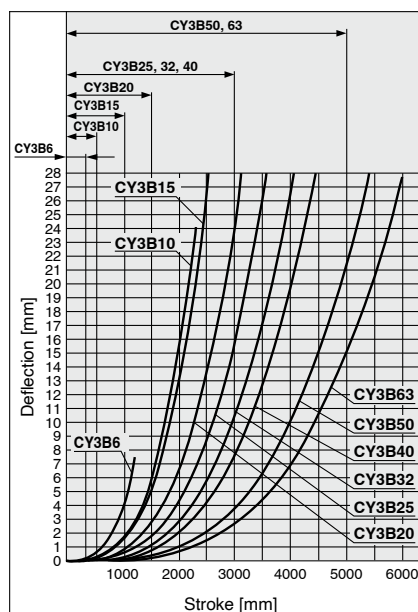
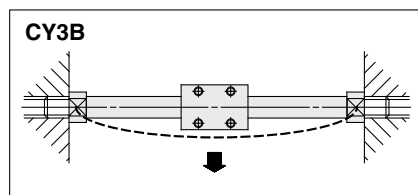

* The above deflection data represent values at the time when the external sliding part moves to the middle of the stroke.

2 Max. Weight of Connection Bracket to the Body

The CY3B series is guided by an external axis (such as a linear guide) without directly mounting the load. When designing a metal bracket to connect the load, make sure that its weight will not exceed the value in the table on the right.

(For connection methods, refer to the Operation Manual.)

Max. Connection Bracket Weight

Model	Max. connection bracket weight (W _{Bmax}) [kg]
CY3B6	0.2
CY3B10	0.4
CY3B15	1.0
CY3B20	1.1
CY3B25	1.2
CY3B32	1.5
CY3B40	2.0
CY3B50	2.5
CY3B63	3.0

3 Allowable Driving Force

Selection procedure

1. Find the drive resisting force F_n [N] when moving the load horizontally.
2. Find the distance L_o [cm] from the point of the load where driving force is applied, to the centre of the cylinder shaft.
3. Select the bore size from L_o and F_n , based on data (A).

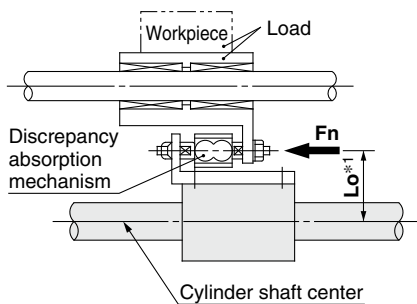

Selection example

Given a load drive resisting force of $F_n = 100$ [N] and a distance from the cylinder shaft centre to the load application point of $L_o = 8$ cm, find the intersection point by extending upward from the horizontal axis of data (A) where the distance from the shaft centre is 8 cm, and then extending to the side, find the allowable driving force on the vertical axis.

Models suitable in satisfying the requirement of 100 [N] are the **CY3B32** or **CY3B40**.

*1 The L_o point from the cylinder shaft centre is the moment working point between the cylinder and the load section.

<Data (A) : Distance from cylinder shaft centre — Allowable driving force>

CY3B6

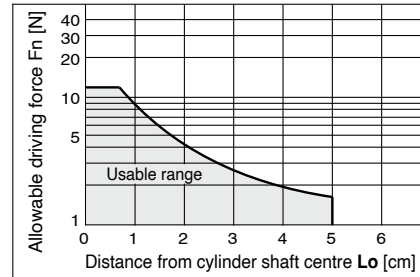

CY3B32

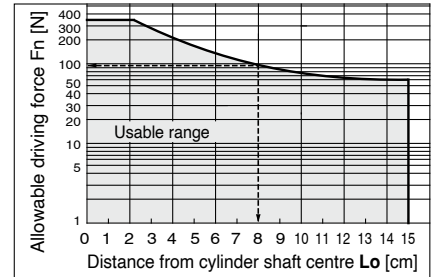

CY3B10

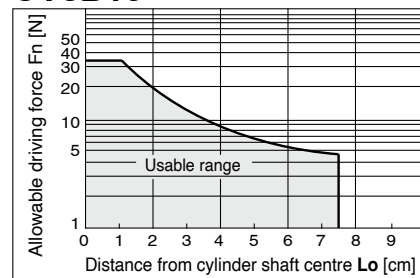

CY3B40

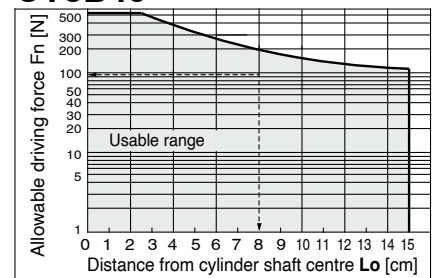

CY3B15

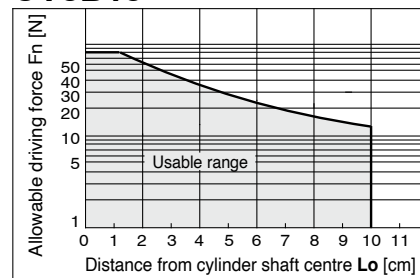

CY3B50

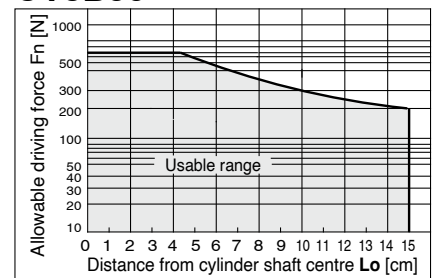

CY3B20

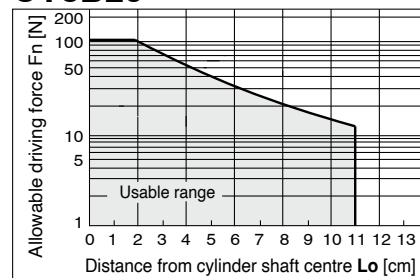

CY3B63

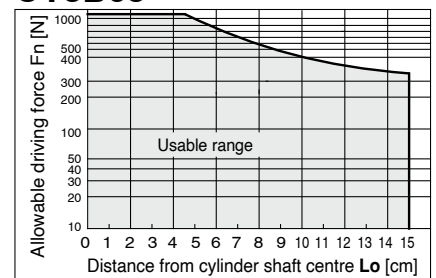

CY3B25

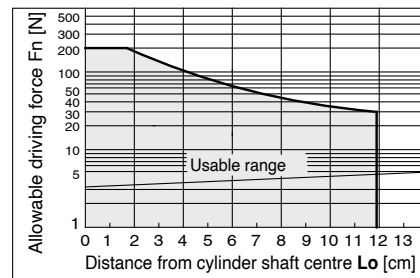

Intermediate Stop

4 Stop with Air Pressure Circuit

When performing an intermediate stop of a load using an air pressure circuit, operate at or below the kinetic energy shown in the table on the right. Use caution, as operation when exceeding the allowable value can result in breaking of the magnetic coupling.

When the cylinder is operated at full stroke without an external stopper, a similar condition may result. Therefore, use the product with the kinetic energy shown in the table on the right or below.

When an intermediate stop is performed by means of an air pressure circuit, the body stopping accuracy is not high. If a high stopping accuracy is required, consider positioning with an external stopper.

For vertical actuation, intermediate stop with a pneumatic circuit is not possible. In this case as well, consider the intermediate stop method using an external stopper.

(Reference values)

Bore size [mm]	Model	Allowable kinetic energy for intermediate stop (Es) [J]
6	CY3B6	0.007
10	CY3B10	0.03
15	CY3B15	0.13
20	CY3B20	0.24
25	CY3B25	0.45
32	CY3B32	0.88
40	CY3B40	1.53
50	CY3B50	3.12
63	CY3B63	5.07

5 Stop with External Stopper

Intermediate stopping of load with an external stopper, etc.

When stopping a load in mid-stroke using an external stopper, etc., operate within the operating pressure limits shown in the table on the right. Use caution, as operation at a pressure exceeding these limits can result in breaking of the magnetic coupling.

Bore size [mm]	Model	Operating pressure limit for intermediate stop (Ps) [MPa]
6	CY3B6	0.55
10	CY3B10	0.55
15	CY3B15	0.65
20	CY3B20	0.65
25	CY3B25	0.65
32	CY3B32	0.65
40	CY3B40	0.65
50	CY3B50	0.65
63	CY3B63	0.65

Stroke End Stopping Method

When stopping a load having a large inertial force at the stroke end, tilting of the body and damage to the bearings and cylinder tube may occur. (Refer to Fig. 1.)

As shown in Fig. 2, a shock absorber should be used together with the stopper, and thrust should also be transmitted from the centre of the body so that tilting will not occur.

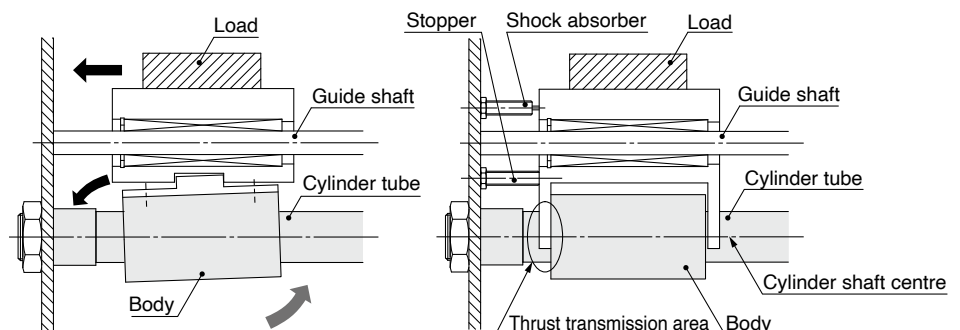

Fig. 1

Fig. 2

Magnetically Coupled Rodless Cylinder Basic Type

CY3B Series

∅ 6, ∅ 10, ∅ 15, ∅ 20, ∅ 25, ∅ 32, ∅ 40, ∅ 50, ∅ 63

How to Order



Basic type

CY3B 25 - **300 Z** -

Basic type

Made to Order
Refer below for details.

Bore size

6	6 mm
10	10 mm
15	15 mm
20	20 mm
25	25 mm
32	32 mm
40	40 mm
50	50 mm
63	63 mm

Standard stroke

Refer to the standard stroke table shown below.

Port thread type

Symbol	Type	Bore size
-	M thread	6, 10, 15
	Rc	20, 25, 32, 40, 50, 63
TN	NPT	
TF	G	

Standard Strokes

Bore size [mm]	Standard stroke [mm]	Manufacturable stroke [mm]
6	50, 100, 150, 200	20 to 300
10	50, 100, 150, 200, 250, 300	20 to 500
15	50, 100, 150, 200, 250, 300, 350, 400, 450, 500	20 to 1000
20	100, 150, 200, 250, 300, 350, 400, 450, 500, 600, 700, 800	25 to 1500
25		25 to 3000
32		25 to 3000
40	100, 150, 200, 250, 300, 350, 400, 450, 500, 600, 700, 800, 900, 1000	25 to 3000
50		40 to 5000
63		40 to 5000

Symbol

Rubber bumper (Magnet type)

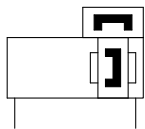

Made to Order: Individual Specifications
(For details, refer to pages 8-1 to 8-3.)

Symbol	Specifications
-X116	Hydro specifications
-X132	Air supply port relocated in axial direction
-X160	High speed specifications
-X168	Helical insert thread specifications
-X206	Added mounting tap positions for slider
-X210	Non-lubricated exterior specifications
-X322	Outside of cylinder tube with hard chrome plated
-X324	Non-lubricated exterior specifications (with dust seal)

* Long stroke type (XB11) applies to the strokes exceeding 2000 mm.

* The longer the stroke, the larger the amount of deflection in a cylinder tube. Pay attention to the mounting bracket and clearance value.

* Intermediate stroke is available in 1 mm increments.

Specifications

Bore size [mm]	6	10	15	20	25	32	40	50	63
Fluid	Air								
Proof pressure	1.05 MPa								
Max. operating pressure*1	0.7 MPa								
Min. operating pressure	0.16	0.16	0.16	0.16	0.15	0.14	0.12	0.12	0.12
Ambient and fluid temperatures	-10 to 60 °C (No freezing)								
Piston speed	50 to 500 mm/s								
Cushion	Rubber bumper								
Lubrication	Not required (Non-lube)								
Stroke length tolerance [mm]	0 to 250 st: $^{+1.0}_0$, 251 to 1000 st: $^{+1.4}_0$, 1001 st or more: $^{+1.8}_0$								
Mounting orientation	Horizontal, Inclined, Vertical								
Mounting nut (2 pcs.)	Standard equipment (Accessory)								
Magnet holding force [N]	19.6	53.9	137	231	363	588	922	1471	2256

*1 Note that to perform an intermediate stop with an external stopper, the required operating pressure limit is the pressure explained in "Stop with External Stopper" on page 5.

CY3B Series

Theoretical Cylinder Thrust

Caution When calculating the actual thrust, design should consider the min. operating pressure.

Ø 6, Ø 10

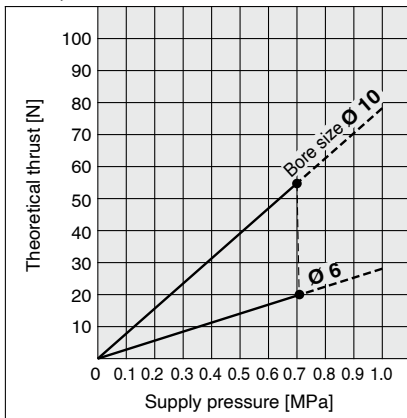

Ø 15, Ø 20, Ø 25, Ø 32, Ø 40

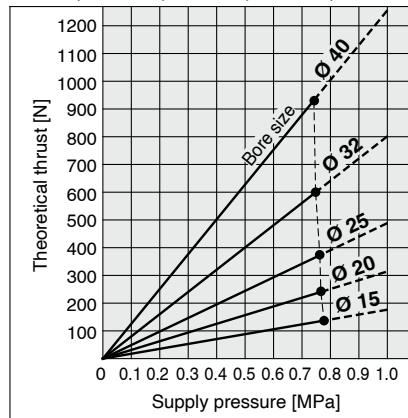

Ø 50, Ø 63

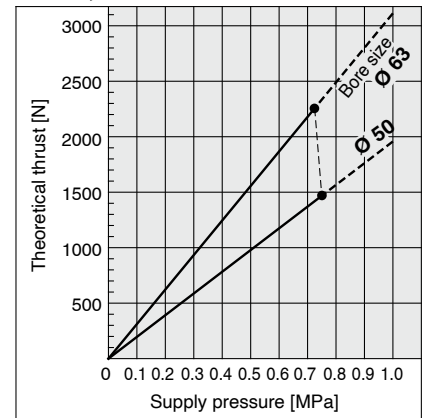

Weight

Unit: kg

Bore size [mm]	6	10	15	20	25	32	40	50	63
Basic weight (at 0 st)	0.039	0.080	0.228	0.344	0.591	1.06	1.80	3.04	4.70
Additional weight per 50 mm of stroke	0.004	0.014	0.015	0.020	0.023	0.033	0.040	0.077	0.096

Calculation method/Example: **CY3B32-500Z** Basic weight 1.06 kg
 Additional weight 0.033/50 st } 1.06 + 0.033 x 500 ÷ 50 = 1.39 kg
 Cylinder stroke 500 st

Replacement Parts: Seal Kit

CY3B6, 10-□Z

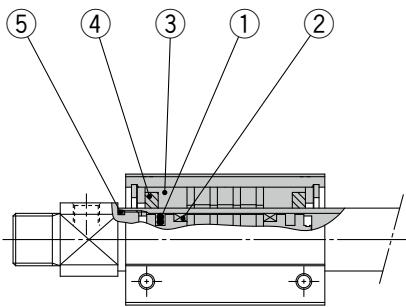

CY3B15 to 40-□Z

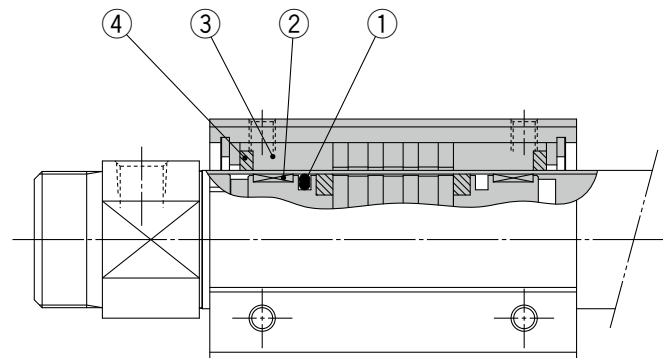

Component Parts

No.	Description
1	Piston seal
2	Wear ring A
3	Wear ring B
4	Lube-retainer B
5	Cylinder tube gasket

Seal Kit/Part Nos.

Bore size [mm]	Part no.	Contents
6	CY3B6-Z-PS	① (2 pcs.), ② (4 pcs.), ③ (2 pcs.), ⑤ (2 pcs.)
10	CY3B10-Z-PS	① (1 pc.), ③ (2 pcs.), ④ (2 pcs.), ⑤ (2 pcs.)
15	CY3B15-Z-PS	① (1 pc.), ② (4 pcs.), ③ (2 pcs.), ④ (2 pcs.)
20	CY3B20-Z-PS	① (1 pc.), ② (2 pcs.), ③ (2 pcs.), ④ (2 pcs.)
25	CY3B25-Z-PS	
32	CY3B32-Z-PS	
40	CY3B40-Z-PS	

* As sizes Ø 50 and Ø 63 cannot be disassembled, the seal kit cannot be replaced.

* The seal kit includes a grease pack (10 g).

Order with the following part number when only the grease pack is required.

Grease pack part number: GR-S-010

* For replacement of the Ø 10 wear ring A, please contact SMC.

Dimensions

CY3B6 to 15-□Z

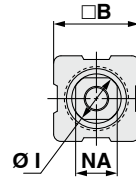
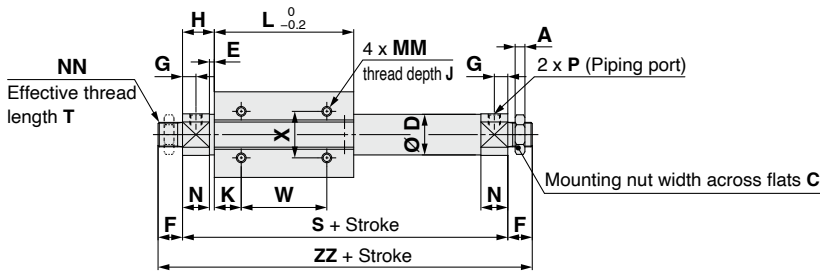

CY3B20 to 40-□Z

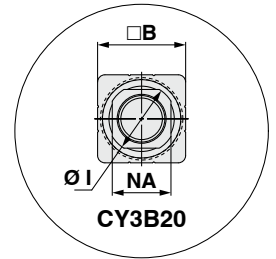
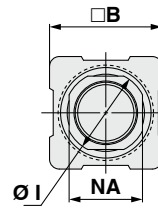
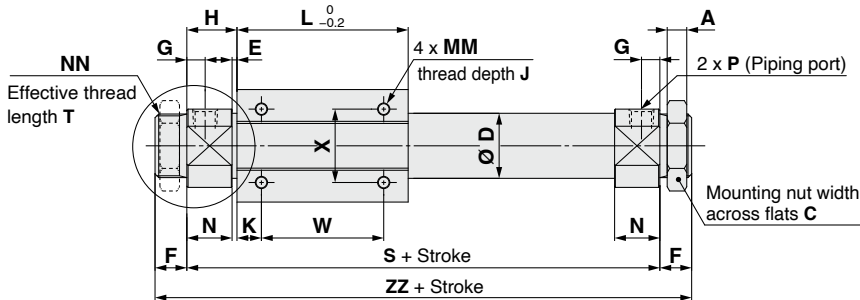

CY3B50, 63-□Z

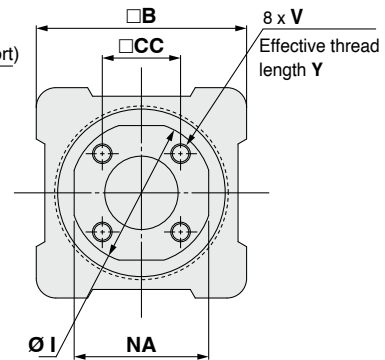
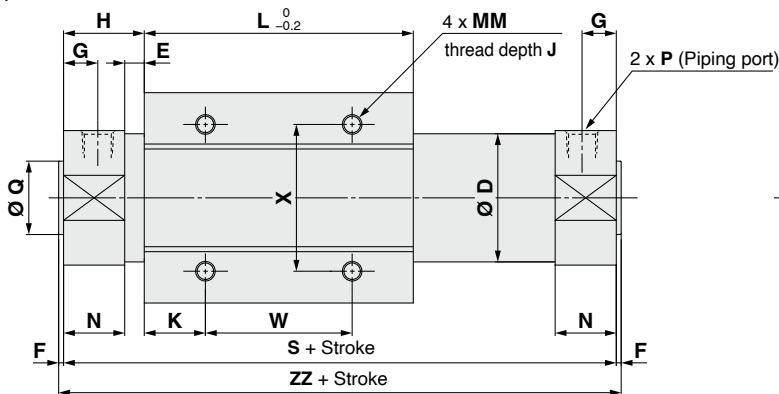

Model	A	B	C	CC	D	E	F	G	H	I	J	K	L	MM	N	NA	NN	Q	S	T	V
CY3B6	4	17	8	—	7.6	4	8	5	13.5	11.9	4.5	5	35	M3 x 0.5	9.5	10	M6 x 1	—	62	6.5	—
CY3B10	4	25	14	—	12	1.5	9	5	12.5	16.9	4.5	4	38	M3 x 0.5	11	14	M10 x 1	—	63	7.5	—
CY3B15	4	35	14	—	16.6	2	10	5.5	13	19.9	6	11	57	M4 x 0.7	11	17	M10 x 1	—	83	8	—
CY3B20	8	36	26	—	21.6	2	13	7.5	20	27.9	6	8	66	M4 x 0.7	18	24	M20 x 1.5	—	106	10	—
CY3B25	8	46	32	—	26.4	2	13	7.5	20.5	33.4	8	10	70	M5 x 0.8	18.5	30	M26 x 1.5	—	111	10	—
CY3B32	8	60	32	—	33.6	2	16	8	22	39.9	8	15	80	M6 x 1	20	36	M26 x 1.5	—	124	13	—
CY3B40	10	70	41	—	41.6	3	16	11	29	49.9	10	16	92	M6 x 1	26	46	M32 x 2	—	150	13	—
CY3B50	—	86	—	32	52.4	8	2	14	33	58.2	12	25	110	M8 x 1.25	25	55	—	30 ^{-0.007/-0.037}	176	—	M8 x 1.25
CY3B63	—	100	—	38	65.4	8	2	14	33	72.2	12	26	122	M8 x 1.25	25	69	—	32 ^{-0.007/-0.043}	188	—	M10 x 1.5

Model	W	X	Y	ZZ	P (Piping port)		
					—	TN	TF
CY3B6	25	10	—	78	M3 x 0.5	—	—
CY3B10	30	16	—	81	M5 x 0.8	—	—
CY3B15	35	19	—	103	M5 x 0.8	—	—
CY3B20	50	25	—	132	Rc1/8	NPT1/8	G1/8
CY3B25	50	30	—	137	Rc1/8	NPT1/8	G1/8
CY3B32	50	40	—	156	Rc1/8	NPT1/8	G1/8
CY3B40	60	40	—	182	Rc1/4	NPT1/4	G1/4
CY3B50	60	60	16	180	Rc1/4	NPT1/4	G1/4
CY3B63	70	70	16	192	Rc1/4	NPT1/4	G1/4

* Mounting nuts can be screwed on only for the effective thread length of the head cover (T dimension). When mounting a cylinder, consider the thickness of flange, etc.

Mounting Nut: Included in the package (2 pcs.)

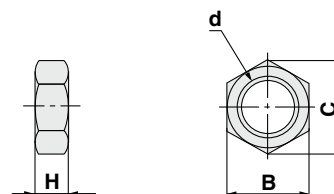

Part no.	Applicable bore size [mm]	d	H	B	C
SNJ-006B	6	M6 x 1.0	4	8	9.2
SNJ-016B	10, 15	M10 x 1.0	4	14	16.2
SN-020B	20	M20 x 1.5	8	26	30
SN-032B	25, 32	M26 x 1.5	8	32	37
SN-040B	40	M32 x 2.0	10	41	47.3

* Mounting nuts are not available for Ø 50 and Ø 63.

Serie applicabile

N°	Simbolo	Specifiche/Descrizione	Diametro [mm]
1	-X116	Specifiche idrauliche	Øda 25 a Ø63
2	-X132	Attacchi di alimentazione assiali	Øda 6 a Ø63
3	-X160	Alta velocità	Øda 20 a Ø63
4	-X168	Filettature con inserto elicoidale	Øda 20 a Ø63
5	-X206	Fori di montaggio addizionali per cursore	Øda 6 a Ø63
6	-X210	Esterno non lubrificato	Øda 6 a Ø63
7	-X322	Esterno del tubo cilindro con cromatura dura	Øda 15 a Ø63
8	-X324	Esterno non lubrificato (con tenuta antipolvere)	Øda 10 a Ø63

1 Specifiche idrauliche

Simbolo
-X116

Questo tipo è adatto per alimentazione a velocità costante di precisione, arresto intermedio e avanzamento a scatti.

CY3B Diametro Filettatura attacco - Corsa Z - X116

Specifiche idrauliche ●

Specifiche

Diametro applicabile	da Ø25 a Ø63
Fluido	Olio per turbine
Velocità del pistone	da 15 a 300 mm/s

* Le corse e le dimensioni applicabili sono le stesse del prodotto standard.

2 Attacchi di alimentazione assiali

Simbolo
-X132

CY3B Diametro Filettatura attacco - Corsa Z - X132

Attacchi di alimentazione assiali ●

Attacchi di alimentazione assiali sulla testata.

Specifiche

Diametro applicabile	da Ø6 a Ø63
-----------------------------	-------------

* Le corse applicabili sono le stesse del prodotto standard.

* Tutte le dimensioni, ad eccezione delle parti modificate, sono le stesse del prodotto standard.

Dimensioni (Le dimensioni diverse da quelle mostrate di seguito coincidono con quelle del tipo standard).

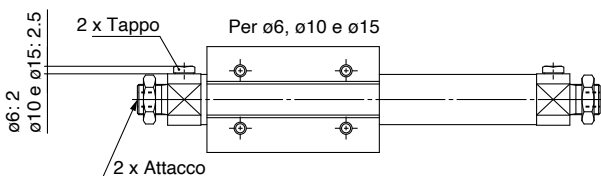

* La dimensione dei filetti dell'attacco è la stessa di quella del prodotto standard.

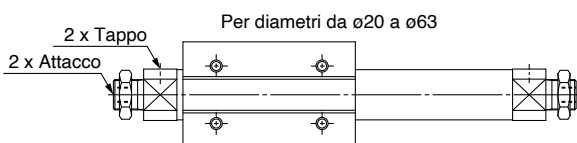

* La dimensione dei filetti dell'attacco è la stessa di quella del prodotto standard.

3 Alta velocità Simbolo **-X160**

CY3B Diametro Filettatura attacco – Corsa **Z – X160**

Alta velocità ●

Questo consente un azionamento del pistone ad alta velocità fino a 1500 mm/s (senza carico), tuttavia, non è applicabile in tutte le condizioni. Contattare SMC per le condizioni operative e altri dettagli.

Specifiche

Diametro applicabile	da Ø 20 a Ø 63
-----------------------------	----------------

- * Quando si utilizza questo cilindro a una velocità che supera il limite del prodotto standard (max. 500 mm/s), assicurarsi di installare un deceleratore idraulico, ecc.
- * La velocità del pistone può variare in base alle condizioni operative. Per ulteriori dettagli, contattare SMC o il rappresentante di vendita più vicino.
- * Quando utilizzato in modo continuo, la velocità potrebbe diminuire nel tempo a causa della riduzione della lubrificazione delle parti scorrevoli, dell'usura delle stesse e di fattori ambientali. Pertanto, è importante riapplicare il grasso regolarmente.
- * Le corse e le dimensioni applicabili sono le stesse del prodotto standard.

4 Filettature con inserto elicoidale Simbolo **-X168**

CY3B Diametro Filettatura attacco – Corsa **Z – X168**

Filettature con inserto elicoidale ●

Un prodotto con filettature a inserto elicoidale che consente di aumentare la resistenza delle viti di montaggio

Specifiche

Diametro applicabile	da Ø 20 a Ø 63
-----------------------------	----------------

- * Le corse e le dimensioni applicabili sono le stesse del prodotto standard.

5 Fori di montaggio aggiuntivi per cursore Simbolo **-X206**

CY3B Diametro Filettatura attacco – Corsa **Z – X206**

Fori di montaggio aggiuntivi per cursore ●

Aggiunti fori di montaggio sulla superficie opposta alle posizioni standard.

Specifiche

Diametro applicabile	da ø6 a ø63
-----------------------------	-------------

- * Le corse applicabili sono le stesse del prodotto standard.
- * Tutte le dimensioni, ad eccezione delle parti modificate, sono le stesse del prodotto standard.

Dimensioni (Le dimensioni diverse da quelle mostrate di seguito coincidono con quelle del tipo standard).

4 x Fori di montaggio aggiunte

La dimensione dei filetti è la stessa del modello standard.

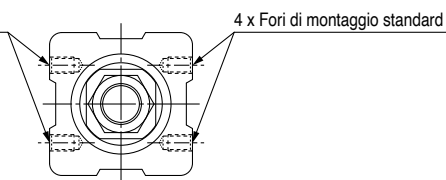

6 Esterno non lubrificato Simbolo **-X210**

CY3B Diametro Filettatura attacco – Corsa **Z – X210**

Esterno non lubrificato ●

Non è applicato grasso sulla superficie esterna del cilindro. Si consiglia di utilizzare questo tipo in ambienti particolari in cui il prodotto standard provoca difetti di lubrificazione.

Contattare SMC se sono necessarie misure di prevenzione contro la ruggine o corpi estranei, in quanto tali misure devono essere valutate caso per caso.

- * Si consiglia di installare una copertura di protezione se il prodotto viene utilizzato in un ambiente dove corpi estranei, come polvere di carta, potrebbero accumularsi nelle parti scorrevoli del cilindro.

Specifiche

Diametro applicabile	da ø6 a ø63
-----------------------------	-------------

- * Le corse e le dimensioni applicabili sono le stesse del prodotto standard.

Costruzione

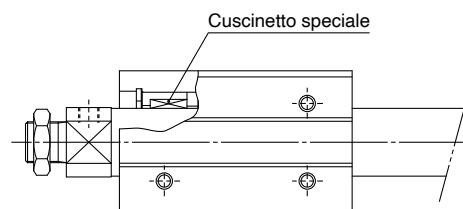

CY3B Series

Made to Order: Individual Specifications 2

Please contact SMC for detailed dimensions, specifications, and lead times.



7 Outside of Cylinder Tube with Hard Chrome Plated Symbol **-X322**

CY3B Bore size Port thread type - Stroke Z - X322

Outside of cylinder tube with hard chrome plated ●

The cylinder tube outer circumference is plated with hard chrome, which further reduces bearing abrasion.

* The maximum stroke is 3500 st, or the maximum stroke for the standard type.

Specifications

Applicable bore size	Ø 15 to Ø 63
-----------------------------	--------------

* The dimensions are the same as those of the standard product.

Construction

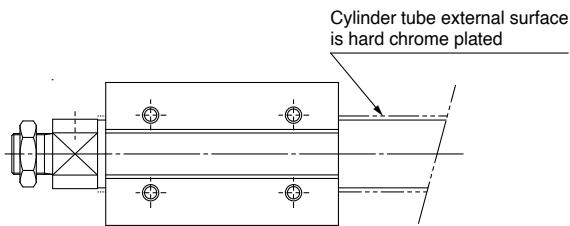

8 Non-lubricated Exterior Specifications (with Dust Seal) Symbol **-X324**

CY3B Bore size Port thread type - Stroke Z - X324

Non-lubricated exterior specifications (with dust seal) ●

No grease is applied to the external surface of the cylinder.

It is recommended to use this type in a special environment where standard product causes lubrication failure.

A felt dust seal is mounted to the external sliding part of the cylinder tube. Contact SMC if rust prevention measures are required, as we need to consider such measures on an individual basis.

* Although a felt dust seal is installed, foreign matter might be caught in the sliding parts of the cylinder. In that instance, consider installing a protective cover.

Specifications

Applicable bore size	Ø 10 to Ø 63
-----------------------------	--------------

* The applicable strokes and dimensions are the same as those of the standard product.

Construction

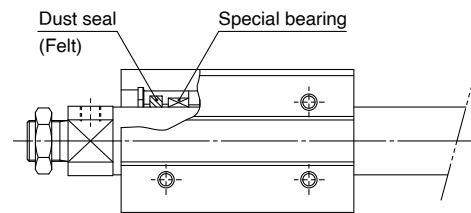



CY3B Series Specific Product Precautions

Be sure to read this before handling the products. Refer to the back cover for safety instructions. For actuator and auto switch precautions, refer to the "Handling Precautions for SMC Products" and the "Operation Manual" on the SMC website: <https://www.smc.eu>

Handling

Warning

- Pay attention to the space between the head cover and the body.**
Take sufficient care to avoid getting your hands or fingers caught when the cylinder is operated.
- Do not apply a load to a cylinder which is greater than the allowable value stated in the Model Selection.**
Applying an improper load may cause malfunctions.
- Do not use the cylinder in an environment where the cylinder is exposed to moisture, adhesive foreign matter, dust, or liquid such as water or cutting fluid.**
If the cylinder is used in an environment where the lubrication of the cylinder sliding parts is compromised, please contact SMC.
- When applying grease to the cylinder, use the grease that has already been applied to the product. Refer to page 7 for the grease pack.**

Mounting

Caution

- Take care to avoid nicks or other damage on the outside surface of the cylinder tube.**
This can lead to damage of the wear ring and Lube-retainer, which in turn can cause malfunctions.
- Pay attention to any connections with any other axis.**
As the external slider rotates, pay attention not to obstruct the floating at the time of connection with another axis.
- Do not operate with the magnetic coupling out of position.**
In case the magnetic coupling is out of position, push the external slider back into the correct position by hand at the end of the stroke (or correct the piston slider with air pressure).
- Be sure that both end covers are secured to the mounting surface before operating the cylinder.**
Avoid operation with the external slider secured to the surface.

Mounting

Caution

- Do not apply a lateral load to the external slider.**
When a load is mounted directly to the cylinder, variations in the alignment of each shaft centre cannot be assimilated, which results in the generation of a lateral load that can cause malfunctions. (Fig. 1) The cylinder should be operated using a connection method which allows for assimilation of shaft alignment variations and deflection due to the cylinder's self-weight. A drawing of a recommended mounting is shown in Fig. 2.

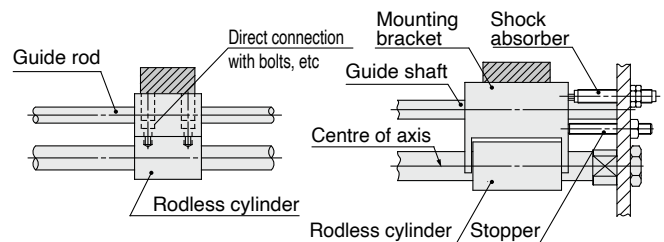

Variations in the load and cylinder shaft alignment cannot be assimilated, resulting in malfunction.

Shaft alignment variations are assimilated by providing clearance for the mounting bracket and cylinder. Moreover, the mounting bracket is extended above the cylinder shaft centre, so that the cylinder is not subjected to moment. Provide clearance so that the cylinder is able to operate smoothly within the min. operating pressure range for a full stroke.

Fig. 1. Incorrect mounting

Fig. 2. Recommended mounting

- Careful alignment is necessary when connecting to a load having an external guide mechanism.**
As the stroke becomes longer, variations in the centre axis become larger. Consider using a connection method (floating mechanism) that is able to absorb these variations.
- Use caution regarding the allowable load mass when operating in a vertical direction.**
When using the cylinder in the vertical direction, be sure to use it with a load equivalent to or lower than the allowable load weight (reference value on page 3). If a load exceeding the allowable values is applied, the magnetic coupling will be detached and the cylinder will drop. When using the cylinder, check the use conditions (pressure and load).

Disassembly and Maintenance

Warning

- When disassembling the cylinder, be sure to carefully handle it. The adsorption force of the magnet is very strong.**
Handle with caution when removing the external slider and piston slider from the cylinder tube for maintenance, etc. For details, refer to the Operation Manual.

Safety Instructions

These safety instructions are intended to prevent hazardous situations and/or equipment damage. These instructions indicate the level of potential hazard with the labels of “Caution,” “Warning” or “Danger.” They are all important notes for safety and must be followed in addition to International Standards (ISO/IEC)¹⁾, and other safety regulations.

Danger:

Danger indicates a hazard with a high level of risk which, if not avoided, will result in death or serious injury.

Warning:

Warning indicates a hazard with a medium level of risk which, if not avoided, could result in death or serious injury.

Caution:

Caution indicates a hazard with a low level of risk which, if not avoided, could result in minor or moderate injury.

- 1) ISO 4414: Pneumatic fluid power – General rules and safety requirements for systems and their components.
ISO 4413: Hydraulic fluid power – General rules and safety requirements for systems and their components.
IEC 60204-1: Safety of machinery – Electrical equipment of machines. (Part 1: General requirements)
ISO 10218-1: Robots and robotic devices - Safety requirements for industrial robots - Part 1: Robots.
etc.

Warning

1. The compatibility of the product is the responsibility of the person who designs the equipment or decides its specifications.

Since the product specified here is used under various operating conditions, its compatibility with specific equipment must be decided by the person who designs the equipment or decides its specifications based on necessary analysis and test results. The expected performance and safety assurance of the equipment will be the responsibility of the person who has determined its compatibility with the product. This person should also continuously review all specifications of the product referring to its latest catalogue information, with a view to giving due consideration to any possibility of equipment failure when configuring the equipment.

2. Only personnel with appropriate training should operate machinery and equipment.

The product specified here may become unsafe if handled incorrectly. The assembly, operation and maintenance of machines or equipment including our products must be performed by an operator who is appropriately trained and experienced.

3. Do not service or attempt to remove product and machinery/equipment until safety is confirmed.

1. The inspection and maintenance of machinery/equipment should only be performed after measures to prevent falling or runaway of the driven objects have been confirmed.
2. When the product is to be removed, confirm that the safety measures as mentioned above are implemented and the power from any appropriate source is cut, and read and understand the specific product precautions of all relevant products carefully.
3. Before machinery/equipment is restarted, take measures to prevent unexpected operation and malfunction.

4. Our products cannot be used beyond their specifications. Our products are not developed, designed, and manufactured to be used under the following conditions or environments. Use under such conditions or environments is not covered.

1. Conditions and environments outside of the given specifications, or use outdoors or in a place exposed to direct sunlight.
2. Use for nuclear power, railways, aviation, space equipment, ships, vehicles, military application, equipment affecting human life, body, and property, fuel equipment, entertainment equipment, emergency shut-off circuits, press clutches, brake circuits, safety equipment, etc., and use for applications that do not conform to standard specifications such as catalogues and operation manuals.
3. Use for interlock circuits, except for use with double interlock such as installing a mechanical protection function in case of failure. Please periodically inspect the product to confirm that the product is operating properly.

Caution

We develop, design, and manufacture our products to be used for automatic control equipment, and provide them for peaceful use in manufacturing industries.

Use in non-manufacturing industries is not covered.

Products we manufacture and sell cannot be used for the purpose of transactions or certification specified in the Measurement Act.

The new Measurement Act prohibits use of any unit other than SI units in Japan.

Limited warranty and Disclaimer/Compliance Requirements

The product used is subject to the following “Limited warranty and Disclaimer” and “Compliance Requirements”. Read and accept them before using the product.

Limited warranty and Disclaimer

1. The warranty period of the product is 1 year in service or 1.5 years after the product is delivered, whichever is first.²⁾ Also, the product may have specified durability, running distance or replacement parts. Please consult your nearest sales branch.
 2. For any failure or damage reported within the warranty period which is clearly our responsibility, a replacement product or necessary parts will be provided. This limited warranty applies only to our product independently, and not to any other damage incurred due to the failure of the product.
 3. Prior to using SMC products, please read and understand the warranty terms and disclaimers noted in the specified catalogue for the particular products.
- 2) Vacuum pads are excluded from this 1 year warranty.
A vacuum pad is a consumable part, so it is warranted for a year after it is delivered. Also, even within the warranty period, the wear of a product due to the use of the vacuum pad or failure due to the deterioration of rubber material are not covered by the limited warranty.

Compliance Requirements

1. The use of SMC products with production equipment for the manufacture of weapons of mass destruction (WMD) or any other weapon is strictly prohibited.
2. The exports of SMC products or technology from one country to another are governed by the relevant security laws and regulations of the countries involved in the transaction. Prior to the shipment of a SMC product to another country, assure that all local rules governing that export are known and followed.

Safety Instructions

Be sure to read “Handling Precautions for SMC Products” (M-E03-3) before using.

SMC Corporation (Europe)

Austria	+43 (0)2262622800	www.smc.at	office.at@smc.com
Belgium	+32 (0)33551464	www.smc.be	info@smc.be
Bulgaria	+359 (0)2807670	www.smc.bg	sales.bg@smc.com
Croatia	+385 (0)13707288	www.smc.hr	sales.hr@smc.com
Czech Republic	+420 541424611	www.smc.cz	office.at@smc.com
Denmark	+45 70252900	www.smc.dk	smc.dk@smc.com
Estonia	+372 651 0370	www.smcee.ee	info.ee@smc.com
Finland	+358 207513513	www.smc.fi	smc.fi@smc.com
France	+33 (0)164761000	www.smc-france.fr	supportclient.fr@smc.com
Germany	+49 (0)61034020	www.smc.de	info.de@smc.com
Greece	+30 210 2717265	www.smchellas.gr	sales@smchellas.gr
Hungary	+36 23513000	www.smc.hu	office.hu@smc.com
Ireland	+353 (0)14039000	www.smcautomation.ie	technical.ie@smc.com
Italy	+39 03990691	www.smcitalia.it	mailbox.it@smc.com
Latvia	+371 67817700	www.smc.lv	info.lv@smc.com

Lithuania	+370 5 2308118	www.smclt.lt	info.lt@smc.com
Netherlands	+31 (0)205318888	www.smc.nl	info@smc.nl
Norway	+47 67129020	www.smc-norge.no	post.no@smc.com
Poland	+48 22 344 40 00	www.smc.pl	office.pl@smc.com
Portugal	+351 214724500	www.smc.eu	apoiocliente.pt@smc.com
Romania	+40 213205111	www.smcromania.ro	office.ro@smc.com
Russia	+7 (812)3036600	www.smc.eu	sales@smcru.com
Slovakia	+421 (0)413213212	www.smc.sk	sales.sk@smc.com
Slovenia	+386 (0)73885412	www.smc.si	office.si@smc.com
Spain	+34 945184100	www.smc.eu	post.es@smc.com
Sweden	+46 (0)86031240	www.smc.nu	order.se@smc.com
Switzerland	+41 (0)523963131	www.smc.ch	helpcenter.ch@smc.com
Turkey	+90 212 489 0 440	www.smcturkey.com.tr	satis@smcturkey.com.tr
UK	+44 (0)845 121 5122	www.smc.uk	sales.gb@smc.com
South Africa	+27 10 900 1233	www.smcza.co.za	Sales.za@smc.com