

# IO-Link Compatible 2 in 1 Auto Switch/ Setup Tool

New

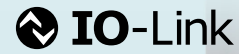

## Looking for a more convenient way to adjust the position of auto switches?

### ■ Reduced setting labour

No need to fine-tune the switch mounting position

### ■ Easy adjustment even in narrow places and on moving parts

The detection position can be set remotely with the switch secured in place.

### ■ Improved productivity

It's possible to discriminate between up to 3 points.

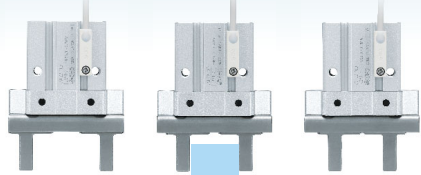

Origin position   Gripping position   Erroneous gripping

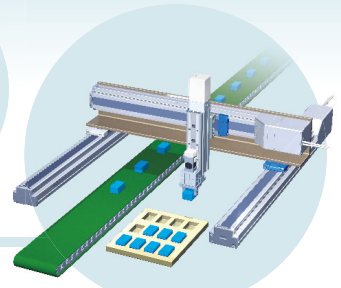
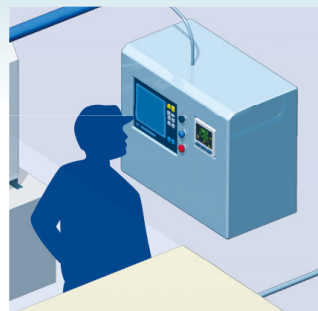

### ■ Reduced auto switch mounting and setting labour

Item	Existing auto switch	<b>New</b> 2 in 1 Auto Switch/Setup Tool
Number of switches	2 pcs.	1 pc.
Mounting	2 pcs.	1 pc.
Setting/Adjustment	2 pcs. (Fine-tuning of the detection positions required)	1 pc. (Setting and adjusting 2 to 3 positions is possible with the setup tool snapshot function)
Wiring	2 pcs.	1 pc.
Switch cable	2 cables	1 cable

**D-MH2** **Series**



CAT.EUS20-311A-UK

# Outputs process data according to the actuator stroke position

## A single switch can discriminate between max. 3 position points

**Repeatability** (Process data):  $\pm 10$

(Converted stroke  $\pm 0.1$  mm)

**Discriminable dimensional difference:** 0.2 mm

- \* The value is in the high-resolution range. The converted stroke value varies depending on the actuator.
- \* For air grippers, this is the value for one side of the finger. When it is converted to the dimension of the workpiece to be gripped, the value is doubled.

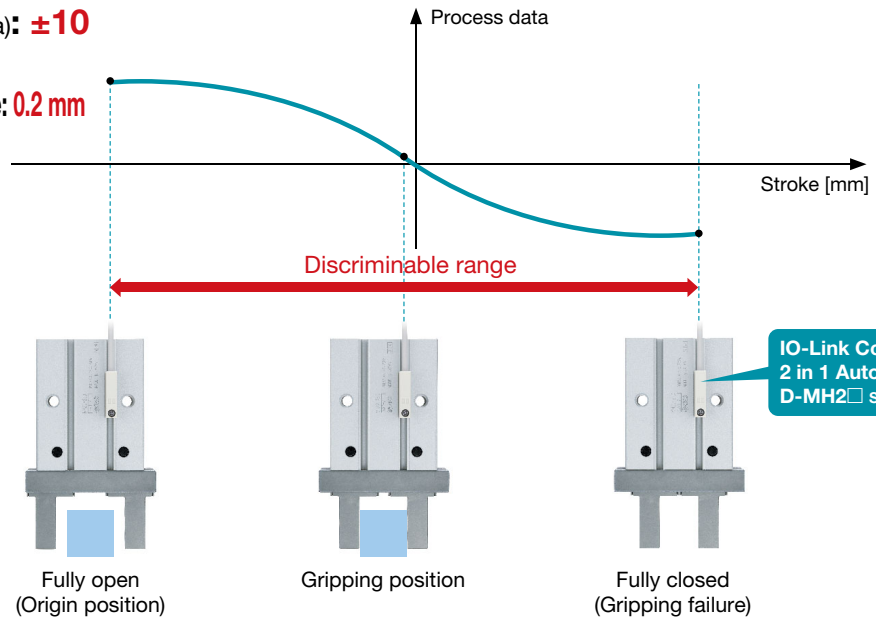

IO-Link Compatible 2 in 1 Auto Switch **D-MH2E** Series

## By using 2 switches, it's possible to discriminate between up to 6 points

If you're using an electric gripper to discriminate between multiple points, we recommend downsizing to an air gripper.

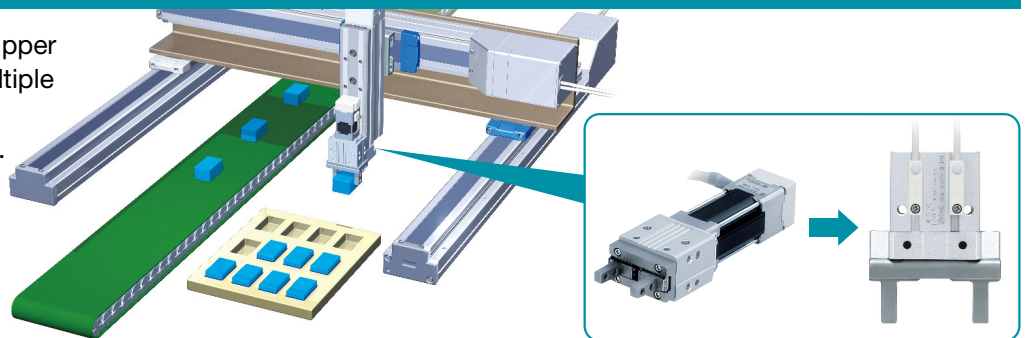

## Detection position setting can be done away from the actuator

Set the detection position via the IO-Link master

Detection position setting via the D-MH2E dedicated setup tool



Can also be used with the 2 in 1 auto switch single unit if there is an IO-Link master

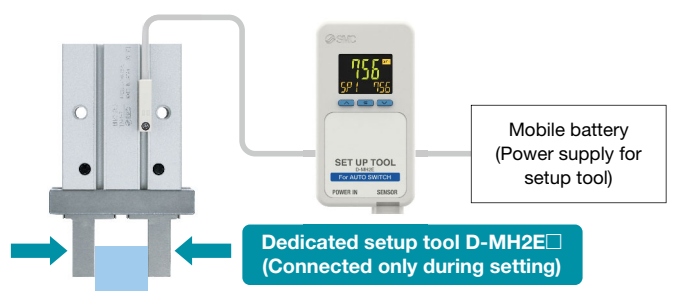

When there is no IO-Link master, the D-MH2E dedicated setup tool can be used to set the detection position. As the tool is powered by a mobile battery, setting can be performed from any location.

\* Does not include the mobile battery or USB-C cable

## How to use D-MH2 and D-MH1 depending the application

- Are you checking the numerical values during daily inspections, etc.?
- Are you using the display sensor monitor/numerical values outside of setting and replacement?
- Are you checking the numerical values on the sensor monitor for constant monitoring?

Display/numerical values are only checked during setting and replacement.

Numerical values are checked during daily inspections, etc.

### 2 in 1 Auto Switch/D-MH2

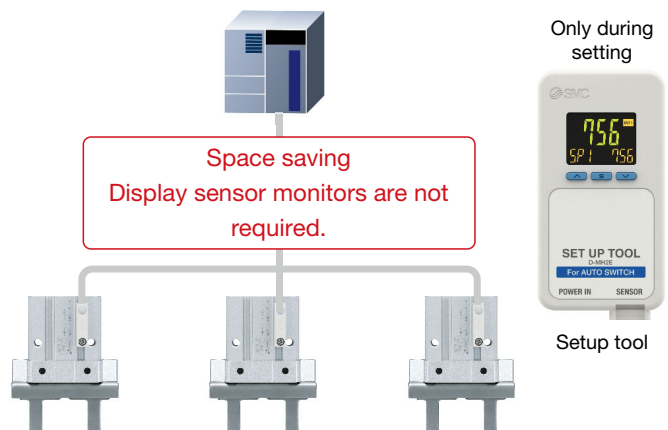

- ➔ The setup tool is only used during setting to set the switch output.
- ➔ When using with IO-Link, setting and numerical value confirmation can be done via the host system.

### Analogue Auto Switch + Display Sensor Monitor/D-MH1

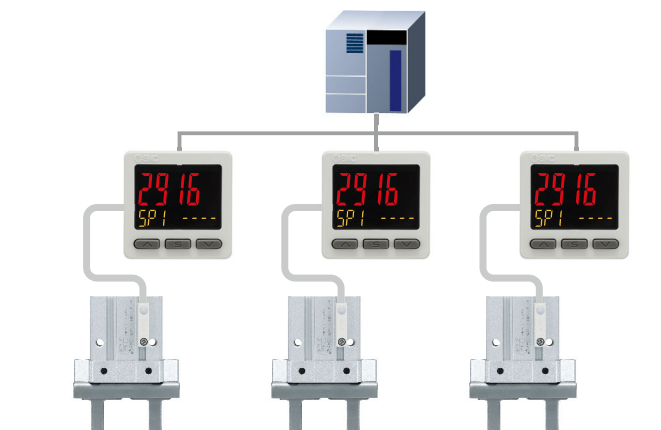

- ➔ Switch output is done through the display sensor monitor.
- ➔ The display sensor monitors can be used to check the numerical values on site.
- ➔ When analogue signals are used instead of the display sensor monitors, numerical value confirmation can be done via the host system.

## Snapshot function for easy switch output setting Reduced setting labour

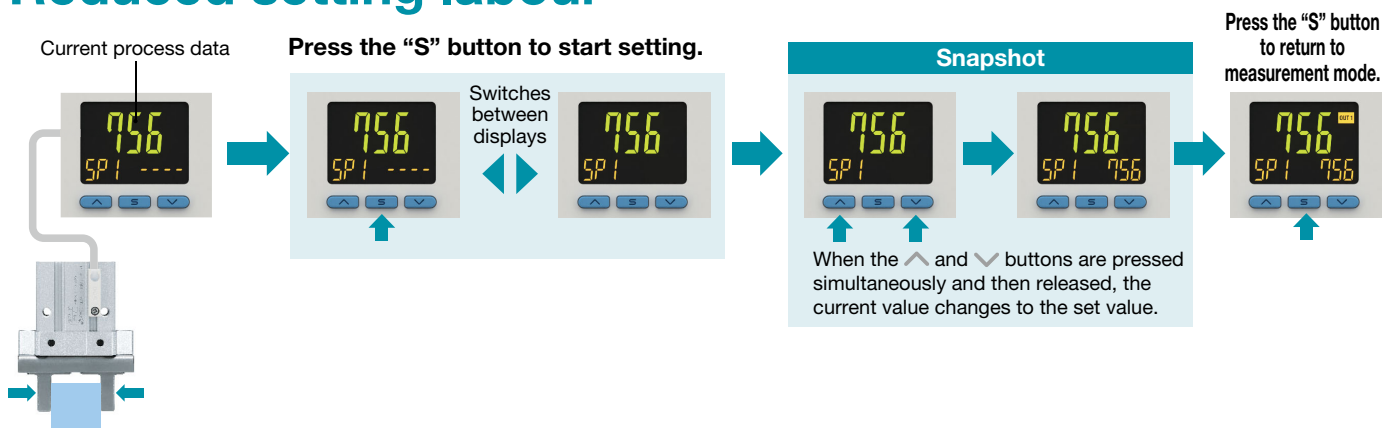

## No protrusion from the body end surface

### Existing auto switch

With protrusion from the air gripper  
(For both the in-line type and the perpendicular type wiring entries)

Wiring entry: In-line type



Wiring entry: Perpendicular type

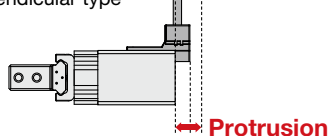

### New IO-Link Compatible 2 in 1 Auto Switch

No protrusion from the air gripper  
(Easy axial mounting for the perpendicular type wiring entry)

\* Excludes the MHZ2-6, MHZJ2-6, JMZH2-12, and MHC2-10

Wiring entry: In-line type

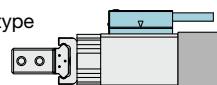

Wiring entry: Perpendicular type

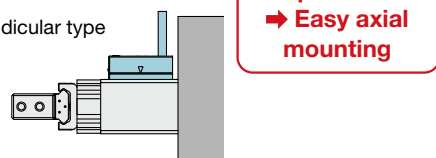

## Improved productivity: A wide range of uses are possible according to the number of set points.

Different usages are possible with the 3-set point type and the 2-set point type.

### 2-setting usage example

● Origin/Gripping position

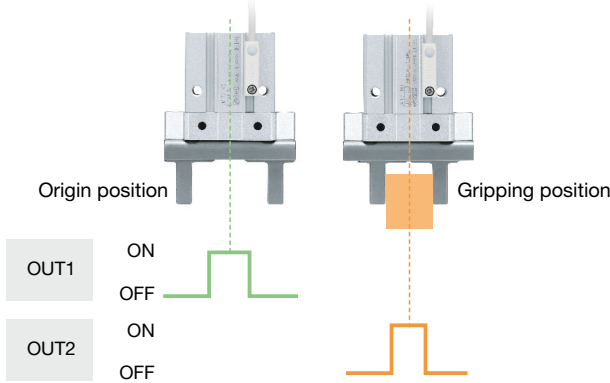

● Simple workpiece recognition

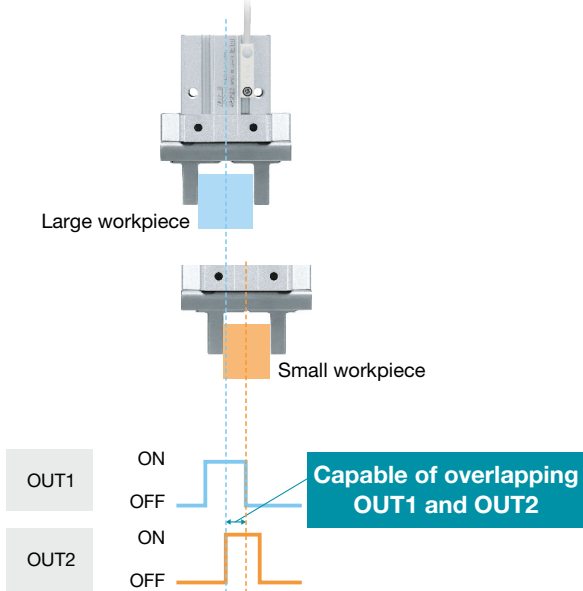

### 3-setting usage example

● Confirmation of the origin/gripping position + erroneous gripping (closed position)

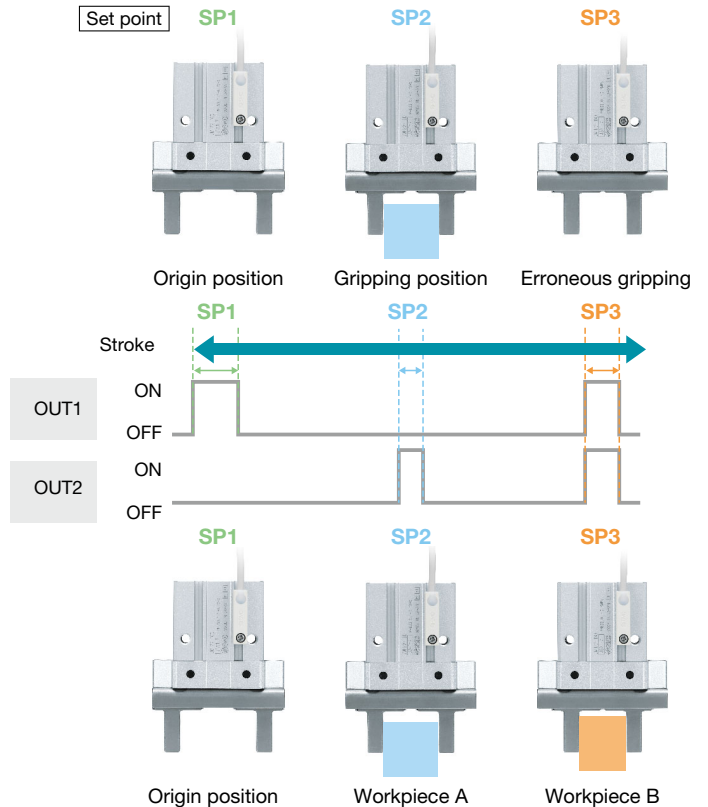

3-setting mode		
Set point	Output terminal	
	OUT1	OUT2
SP1	ON	OFF
SP2	OFF	ON
SP3	ON	ON

- \* SP3 is set to OUT1 + OUT2 simultaneous output.
- \* In 3-setting, it is not possible to set the output range to overlap.
- \* The part numbers of the 3-set point type and the 2-set point type are different. The number of set points cannot be changed.

## Improved productivity: Easy resetting due to position shifting

## The switch output's output range and hysteresis can be set.

The ON width and hysteresis can be changed via the setup tool. (It is possible to set SP1 to 3 individually.)  
The ON width can be used to change the switch output's ON range. Chattering of the switch output can be prevented by setting a hysteresis.

### Relationship between the set point and the output terminal (For 3-setting)

Set point	Output terminal	
	OUT1	OUT2
SP1	ON	OFF
SP2	OFF	ON
SP3	ON	ON

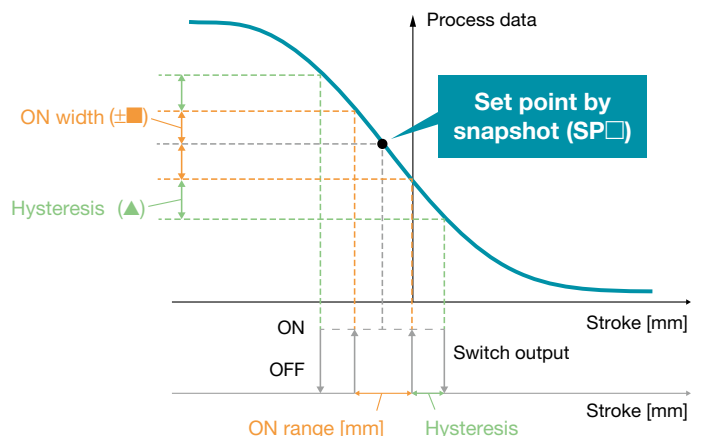

## Difference in mounting method between the 2-in-1 auto switch and the existing product

### Existing Product (Example)

#### Step 1

Fully open the fingers.

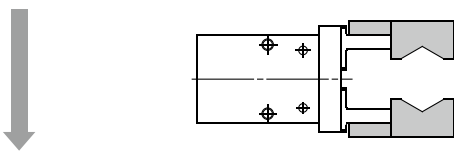

#### Step 2

Insert the auto switch into the switch installation groove in the direction shown in the following drawing.

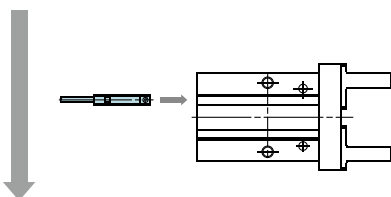

#### Step 3

Slide the auto switch in the direction of the arrow until the indicator light illuminates.

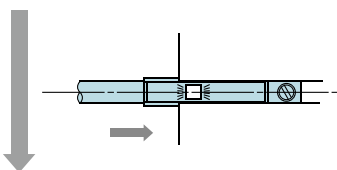

#### Step 4

Slide the auto switch further in the direction of the arrow until the indicator light goes out.

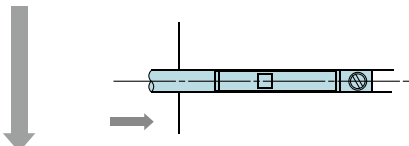

#### Step 5

Move the auto switch in the opposite direction and fasten it at a position 0.3 to 0.5 mm beyond the position where the indicator light illuminates.

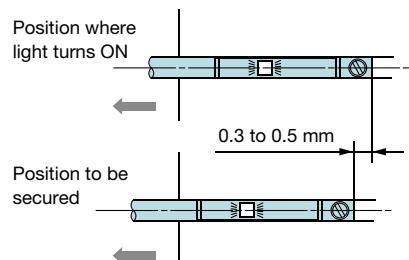

To set the detection point of the second point (and subsequent points), you will be required to prepare a new switch and set it from step 1.

### 2 in 1 Auto Switch (Example)

#### Step 1

Fully open the fingers.

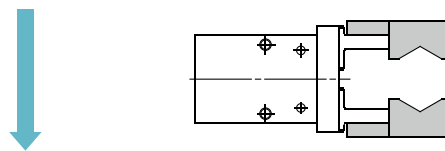

#### Step 2

Insert the auto switch into the switch installation groove in the direction shown in the following drawing. Secure the auto switch at recommended mounting dimension B.

\* When the full stroke can be detected

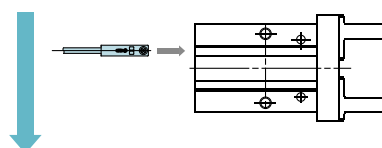

#### Step 3

Set the ON point using the IO-Link master or the D-MH2E dedicated setup tool. (Refer to page 1.)

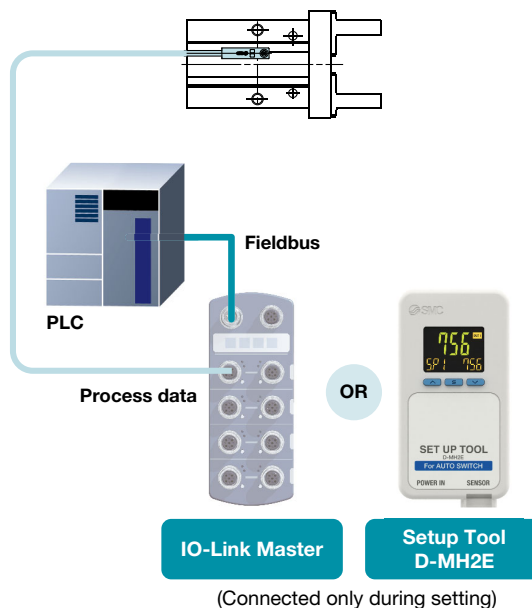

Setting the second point (and subsequent points) can be done by setting the finger to the desired state and then performing step 3. The ON point can be set without adding a switch or making fine adjustments to the mounting position.

**Allows for a reduction in the number of switches and makes switch mounting and adjustment easier**

# IO-Link compatible

Visualisation of operation/equipment status/Remote monitoring and control by communication

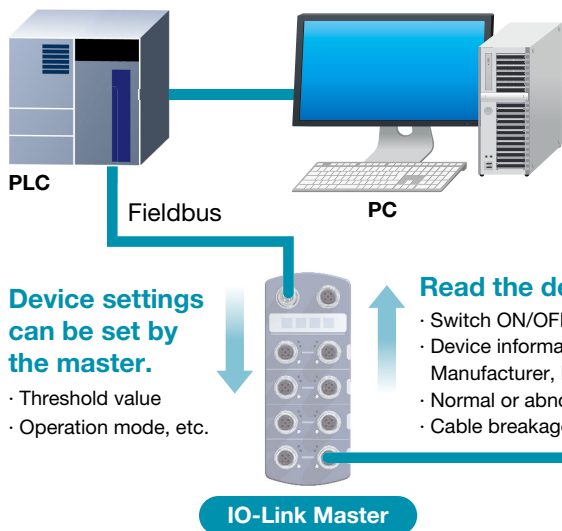

### Configuration File (IODD File)\*1

- Manufacturer • Product part no.
- Set value

#### \*1 IODD File:

IODD is an abbreviation of IO Device Description. This file is necessary for setting the device and connecting it to a master. Save the IODD file on the PC to be used to set the device prior to use.



IO-Link is an open communication interface technology between the sensor/actuator and the I/O terminal that is an international standard: IEC 61131-9.

**Device settings can be set by the master.**

- Threshold value
- Operation mode, etc.

### Read the device data.

- Switch ON/OFF signal and position measurement value
- Device information: Manufacturer, Product part number, Serial number, etc.
- Normal or abnormal device status
- Cable breakage

### 2 in 1 Auto Switch

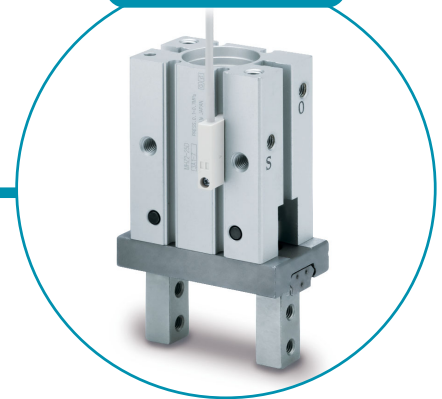

## 2 in 1 auto switch IO-Link specifications

IO-Link version: V1.1  
 Communication speed: 38.4 [kbps] (COM2)  
 Shortest data update cycle: 3.2 ms

### Process Data

Bit offset	Item	Note
0	SW1 output	0: SW*-OFF 1: SW*-ON
1	SW2 output	
2	SW3 output	
3 to 7	—	0
8	Measurement diagnosis	0: Within range 1: Out of range
9	SW1 output allowed/not allowed	0: SW output allowed 1: SW output not allowed
10	SW2 output allowed/not allowed	
11	SW3 output allowed/not allowed	

Bit offset	Item	Note
12 to 13	—	0
14	Error	0: When no errors occur 1: When an error occurs
15	System error	
16 to 31	Position measurement value	16-bit signed integer

Process data is the data which is exchanged periodically between the master and device. This product process data consists of the switch output status and the position measurement value.

\*1 For the 2-point setting, SW3 is 0.

Bit offset	31	30	29	28	27	26	25	24	23	22	21	20	19	18	17	16
Item	Position measurement value															
Bit offset	15	14	13	12	11	10	9	8	7	6	5	4	3	2	1	0
Item	System error	Error	0	0	SW3 output allowed/not allowed	SW2 output allowed/not allowed	SW1 output allowed/not allowed	Measurement diagnosis	0	0	0	0	0	SW3 output*1	SW2 output	SW1 output

### Diagnostics/ Status Monitoring Function

Internal error
Abnormal internal temperature

### List of Functions Settable With the Setup Tool or IO-Link

Function	Description
SW* output point setting (Snapshot function)	The point at which the switch output SW* turns ON or OFF can be set.
SW* output width setting	The switch output SW* output range can be set.
SW* hysteresis setting	The switch output SW* hysteresis can be set.
Delay time setting	It is possible to set the time between when the 2-in-1 auto switch process data set value has been reached and when the ON/OFF output is actually performed.
Digital filter setting	A digital filter can be added to combat 2-in-1 auto switch process data fluctuations.
Changing between N.O. and N.C. switch output	The switch output can be changed between N.O. and N.C.
Switch output PNP/NPN output switching	The switch output can be changed between PNP and NPN.
PD measurement value normal/reversed output switching	The displayed process data can be changed between normal output and reversed output, centring around "0."
Locator function	By turning the function ON, it is possible to make the green LED of the connected 2-in-1 auto switch flash.
DS upload/download	Set values other than the output points, output width, and hysteresis can be uploaded. These uploaded set values can even be downloaded by other 2-in-1 auto switches.
Factory reset mode	If you are unsure of the state of the product, it is possible to return it to its factory settings.

# CONTENTS

## IO-Link Compatible 2 in 1 Auto Switch

### *D-MH2* □ Series



Setup tool  
**D-MH2E** □

How to Order .....	p. 7
Specifications .....	p. 7
Weight .....	p. 7

### **IO-Link Compatible 2 in 1 Auto Switch Setup Tool**

#### **D-MH2E** □ Series

How to Order .....	p. 8
Specifications .....	p. 8
Weight .....	p. 8

Dimensions .....	p. 9
Internal Circuits and Wiring .....	p. 11
Applicable Actuators and 2 in 1 Auto Switch Mounting .....	p. 13
Specific Product Precautions .....	p. 17

\* Similar PSE Sensor Set Up Tool PSE-ST is not available for these sensors.

# IO-Link Compatible

## 2 in 1 Auto Switch

# D-MH2□

CE UK CA  
Series

RoHS

IP67

### How to Order

D-MH2□ C P □ □  
① ② ③ ④

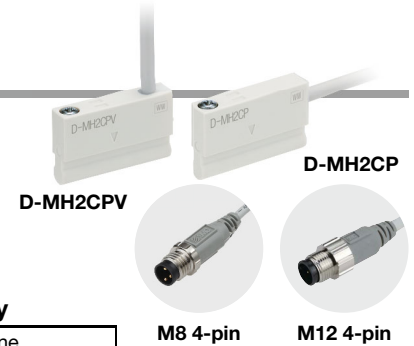

#### ① Number of set points

C	2 points
D	3 points

#### ② Output type

N	NPN output
P	PNP output

#### ③ Electrical entry

—	In-line
V	Perpendicular

#### ④ Lead wire specification

—	0.5 m, Separate line	SBPC	0.5 m, M8 4-pin
M	1 m, Separate line	MBPC	1 m, M8 4-pin
L	3 m, Separate line	SDPC	0.5 m, M12 4-pin
Z	5 m, Separate line	MDPC	1 m, M12 4-pin

- \* The D-MH2□ cannot be ordered with the cylinder or actuator. It must be ordered separately.
- \* M8 and M12 connector specifications are available as made to order.

### Specifications

#### IO-Link Compatible 2 in 1 Auto Switch

Model	D-MH2□	
Power supply voltage	18 to 30 VDC	
Current consumption	25 mA or less (at no load)	
Internal voltage drop	0.5 V or less	
Leakage current	0.5 mA or less	
Max. load current	40 mA (For SW1 and SW2 individually)	
Output specifications	NPN or PNP 2 outputs	
Output repeatability (Process data) (Ambient temperature: 25°C)	±10*1	
Output temperature characteristics (Process data)	±40*2	
Operating time	5 ms or less	
Indicator light	OUT1: Green, OUT2: Red	
Electrical entry	Grommet	
Impact resistance	1000 m/s <sup>2</sup>	
Insulation resistance	50 MΩ or more (500 VDC measured via megohmmeter) (Between the lead wire and case)	
Withstand voltage	1000 VAC for 1 min (Between the lead wire and case)	
Ambient temperature	-10 to 60 °C	
Enclosure	IP67	
Standards	CE/UKCA marking	
IO-Link	Version	V1.1
	Communication speed	COM2 (38.4 kbps)
	Process data size	Input: 4 bytes, Output: 0 bytes
	Min. cycle time	3.2 ms
	Device ID	675 (D-MH2C), 676 (MH2D)
Vendor ID	131	

- \*1 Single switch unit characteristics. When the mounting orientation is uniform and there is no magnetic body or magnetic field disturbance in the surroundings.  
Excluding a deformation of the workpiece or wobbling of the actuator
- \*2 Single switch unit characteristics. The effect of fluctuations in the magnetic force of the magnet itself is excluded.

· Do not apply a strong magnetic field exceeding 200 [mT] to the sensor. Doing so may result in malfunction or accuracy degradation of the 2 in 1 auto switch. Doing so may also cause abnormal operation.

### Weight

Model	D-MH2□ [g]
0.5 m (—)	7
1 m (M)	11
3 m (L)	29
5 m (Z)	46

#### Connector Weight

Connector type	Weight
M8 4-pin (BPC)	4 g
M12 4-pin (DPC)	Approx. 11 g

- \* When a connector is selected, add the above weight.

### Flexible Heavy-duty Lead Wire Specifications

Model		D-MH2□
Sheath	Outside diameter [mm]	Ø 2.6
Insulator	Number of cores	4 (Brown, Black, White, Blue)
	Outside diameter [mm]	Ø 0.6
Conductor	Effective area [mm <sup>2</sup> ]	0.06
	Strand diameter [mm]	0.04
Min. bending radius (Reference value)		17



**How to Order IO-Link Compatible 2-in-1 Auto Switch Setup Tool**

**D - MH2E**

①



**① Connector converter**

—	Without connector converter
<b>A</b>	M8 4-pin socket connector
<b>B</b>	M12 4-pin socket connector
<b>C</b>	Connector for separate line

\* As a connector converter is required to connect the setup tool to the sensor part, order using the part number that includes a connector converter if you do not already possess one.

**Specifications**

**2-in-1 Setting Device**

Model		<b>D-MH2E</b> <input type="checkbox"/>
Applicable sensor		D-MH2 <input type="checkbox"/> (2 in 1 auto switch)
Power supply rating		5 VDC mobile battery with output current of 2 A or more
Current consumption		2 A or less
Process data display range		-1050 to 1050
Process data set range		-1050 to 1050
Connection		Sensor input: Connector Power supply: USB type-C connector
Environmental resistance	Operating temperature range	0 to 45 °C (Stored: -10 to 60 °C) (No freezing or condensation)
	Operating humidity range	Operating humidity range: 35 to 85 %RH (No condensation)
	Enclosure	When connected with connectors of sensor and power supply: IP40
	Withstand voltage	1000 VAC for 1 min between threaded part and housing
	Insulation resistance	50 MΩ or more (500 VDC measured via megohmmeter)
Display	Display type	LCD
	Number of screens	3-screen display (Main screen, Sub screen x 2)
	Display colour	Main screen: Red/Green Sub screen: Orange
Standards		CE/UKCA marking, WEEE directive

- \* Connect this product to a 5 VDC mobile battery with an output current of 2 A or more. Be sure to confirm the mobile battery specifications. When used at a high temperature (above the operating temperature range), malfunction, fire, or burns may result. Be sure to follow the mobile battery usage instructions and precautions.
- \* Do not connect the product to any power supply other than a mobile battery. Doing so may prevent the product from operating or result in a power supply malfunction.
- \* This product may not operate if connected to a mobile battery with a function that automatically turns the power supply OFF according to the mobile battery's current consumption. We recommend using a mobile battery that allows you to turn this function ON/OFF.

**Weight**

	[g]
Body (D-MH2E) (Does not include the cable with connector for sensor connection)	50
M8 4-pin socket connector	10
M12 4-pin socket connector	17
Connector for separate line	15

**Connector Converter Part Nos.**

M8 4-pin socket connector	<b>D-LH03A</b>
M12 4-pin socket connector	<b>D-LH03B</b>
Connector for separate line	<b>D-LH03C</b>

# D-MH2□ Series

## Dimensions

IO-Link compatible 2 in 1 auto switch  
D-MH2□□□□



D-MH2□□□V□

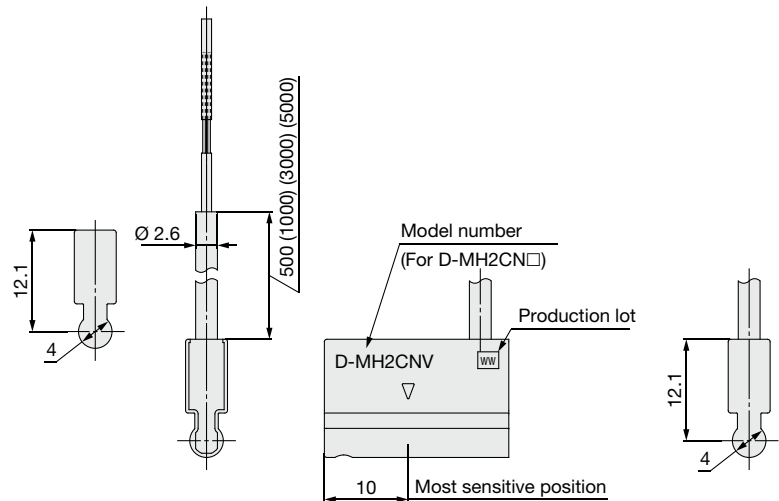
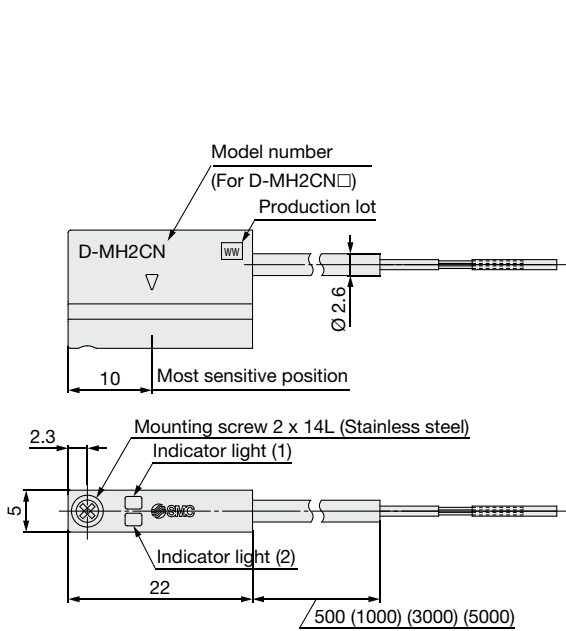

D-MH2□□□V□BPC  
(M8 4-pin)

D-MH2□□□V□DPC  
(M12 4-pin)

D-MH2□□□□BPC  
(M8 4-pin)

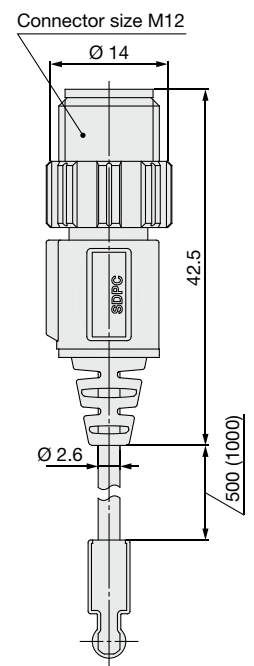
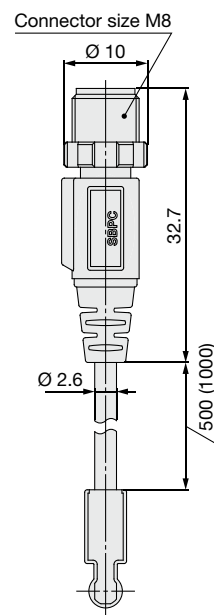
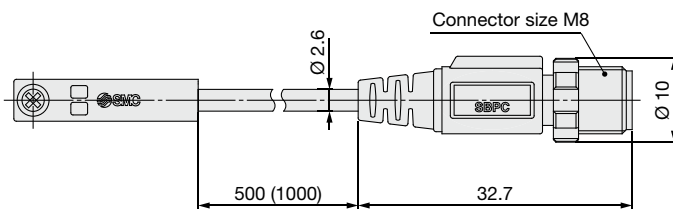

D-MH2□□□□DPC  
(M12 4-pin)

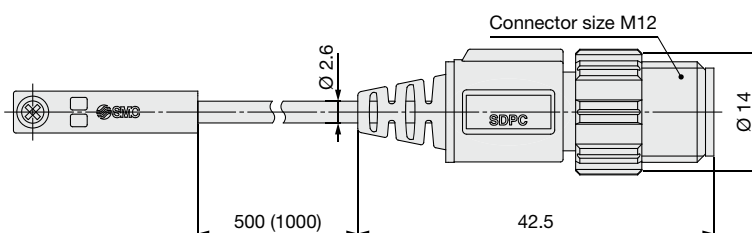

**Dimensions**

**IO-Link compatible 2 in 1 auto switch setup tool  
D-MH2E**

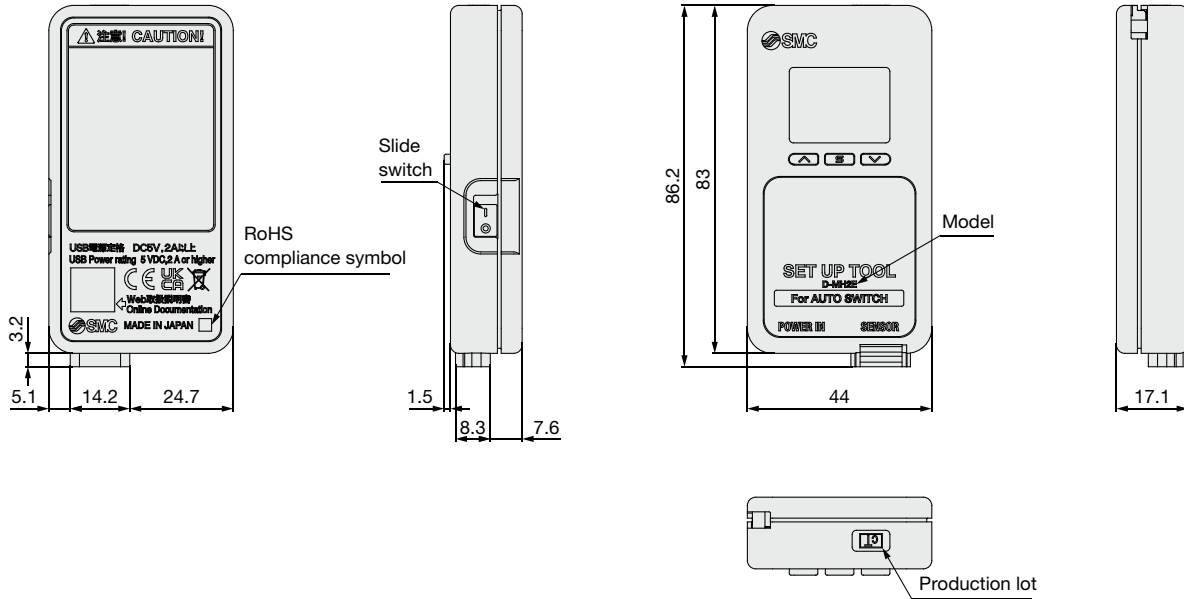
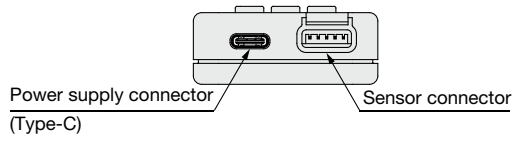

**Connector converter  
D-LH03A**

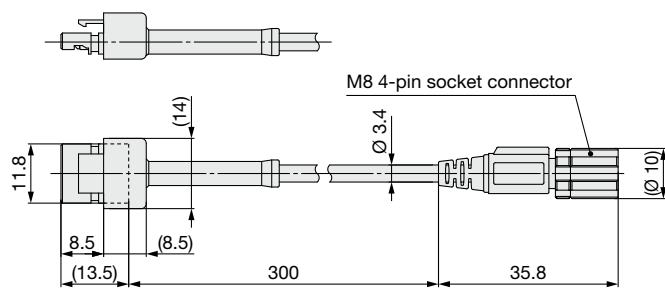

**D-LH03C**

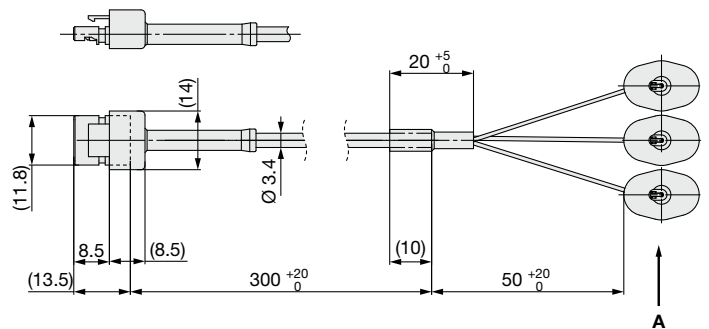

**D-LH03B**

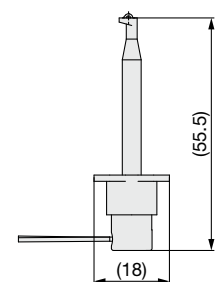
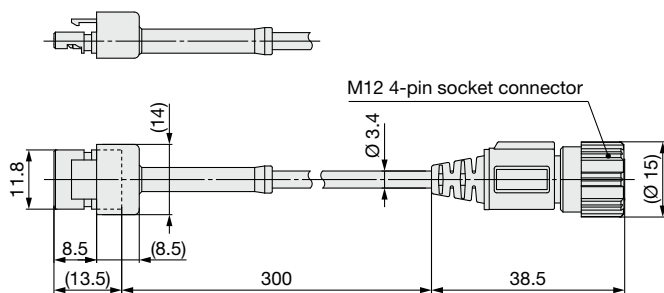

**View A**

## Internal Circuits and Wiring

### IO-Link compatible 2 in 1 auto switch

#### IO-Link mode

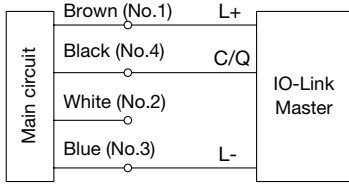

#### SIO mode NPN output

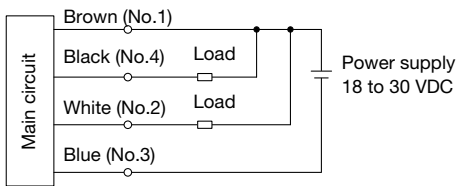

#### PNP output

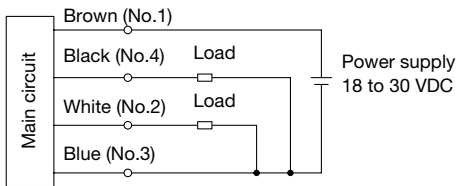

### Setup tool

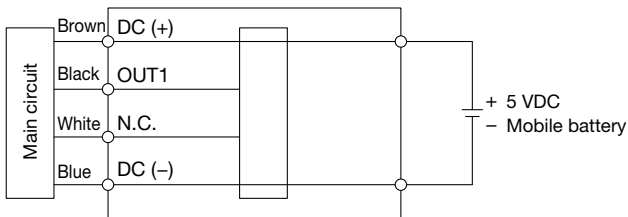

### 2 in 1 Auto Switch M8/M12 Connector Specifications

Pin no.	Voltage input
1	DC (+) (Brown)
2	OUT2 (White)
3	DC (-) (Blue)
4	OUT1 (Black)

Connector type	M8 4-pin	M12 4-pin
Pin arrangement		



# D-MH2□ Series

## Applicable Actuators and 2 in 1 Auto Switch Mounting

### 1. Full-stroke detectable actuator

Position detection can be performed at the full stroke position by mounting the 2 in 1 auto switch at the recommended mounting B dimension.

#### <Recommended mounting B dimension>

Position so that the middle position of the finger aligns with the centre of the sensor (0).

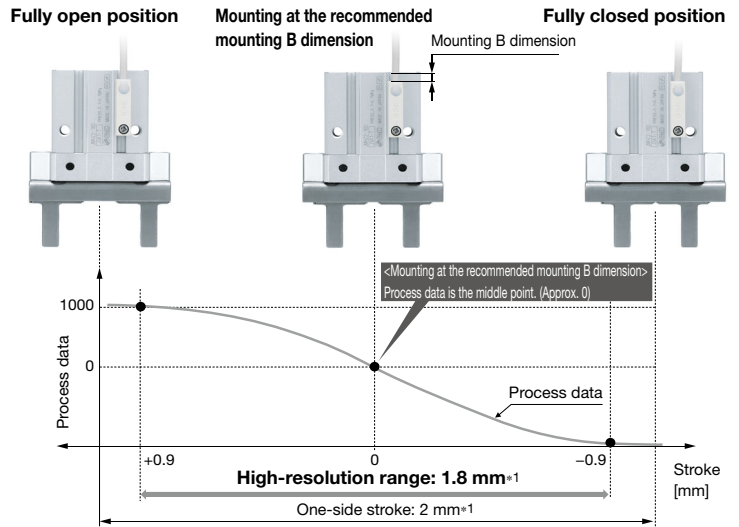

\*1 When mounted on an MHZ2 (Ø 6) air gripper

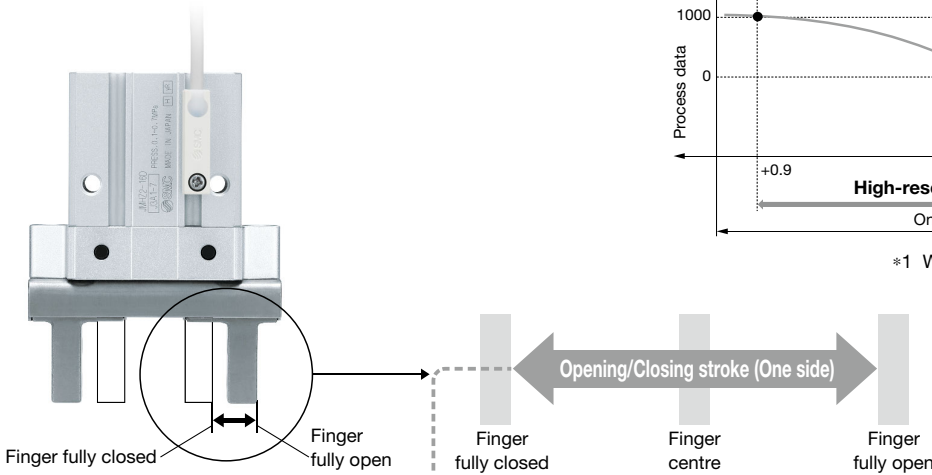

Series/Mounting	Bore size [mm]	Opening/Closing stroke [mm]		
		Both sides	One side	
<b>JMHZ2</b>	12	6	3	
<b>MHZ2/ MHZJ2</b>	Round groove	6	4	2
		10	4	2
		16	6	3
		20	10	5
	Square groove	10	4	2
		16	6	3
	20	10	5	
<b>MHF2(D)</b>	8	8	4	
<b>MDHR3</b>	10	6	3	
<b>MHK2</b>	12	4	2	
	16	6	3	
<b>MHS2/MHS4</b>	16	4	2	
	20	4	2	
	25	6	3	
	32	8	4	
<b>MHS3/ MHSJ3 Ø 16 to Ø 25/ MHSJ3 Ø 16 to Ø 25/ MHSJ3 Ø 16 to Ø 25</b>	16	4	2	
	20	4	2	
	25	6	3	
	32	8	4	
<b>MHSJ3 MHSJ3 MHSJ3</b>	32	8	4	
	40	8	4	
	50	12	6	
<b>MHC2</b>	10	—	—	
	16	—	—	
	20	—	—	
	25	—	—	

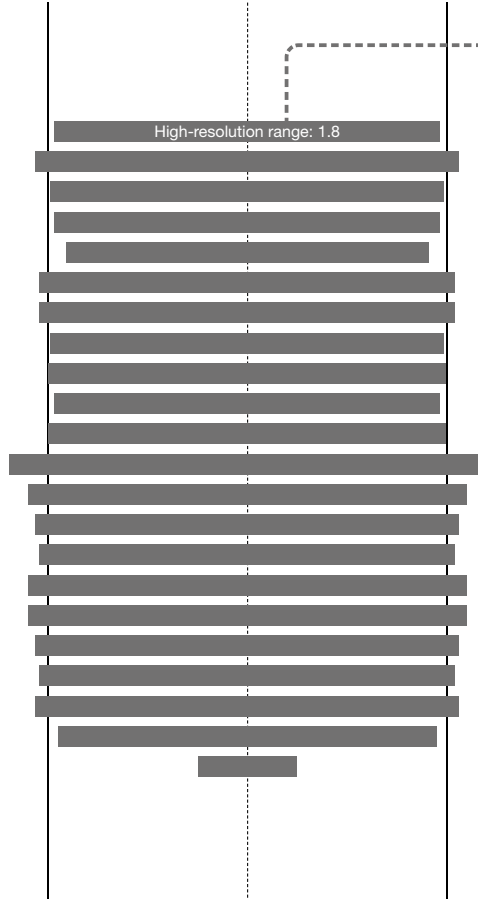

High-resolution range [mm]	Recommended mounting B dimension [mm]	Note
—	-0.3	
1.8	-0.9	
2.3	-1.3	MHZ2 only
3.1	4.8	
4.8	7.7	
1.5	0.3	MHZ2 only
3.2	4.8	MHZ2 only
5.2	7.9	MHZ2 only
3.9	1.2	Short type only
3.0	9.7	
1.8	4.2	
3.0	4.0	
3.1	1.7	
2.7	2.8	
3.5	4.5	
4.4	6.1	
2.7	1.9	
2.7	2.8	
3.5	4.5	
4.4	6.1	MHS3 only
4.5	5.3	
3.7	6.1	
2.0	9.0	
Angle open/ close type	-0.8	
	1.3	
	3.2	
	4.7	

\* All the above values are reference values.

\* There is a possibility of the above values fluctuating significantly depending on the ambient environment. Be sure to conduct a test operation in the actual operating environment.

\* The displayable magnetic force range may be exceeded depending on the mounting position. For details, contact SMC.

## Mounting position

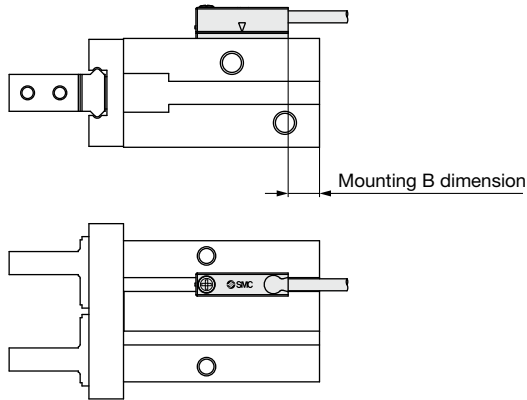

## How to Mount

<For square groove mounting>

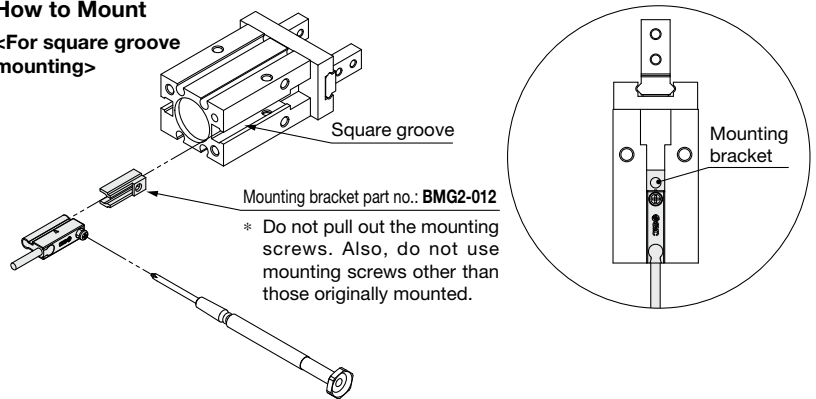

Mounting bracket part no.: **BMG2-012**

\* Do not pull out the mounting screws. Also, do not use mounting screws other than those originally mounted.

Tightening torque: About 0.15 to 0.25 N·m

\* Use a #0 Phillips head screwdriver.

## [High-resolution range with a short stroke]

The high-resolution range is a guide for the range in which the product can discriminate between workpiece differentials of  $\pm 0.1$  mm. When the switch is mounted at the recommended mounting B dimension, the high-resolution range will be the range centred around the approx. 0 point of the centre of the process data. (For grippers, this is the value for one side of the finger. When it is converted to the dimension of the workpiece to be gripped, the value is doubled.) Refer to the operation manual for a detailed explanation of resolution.

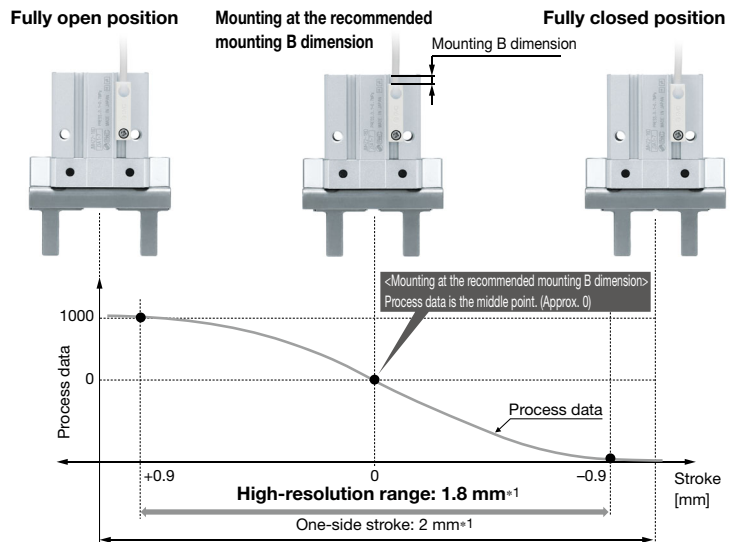

● If the workpiece dimension is changed, the process data will also change. However, if it is mounted at the recommended mounting B dimension, an actuator that can detect full strokes can detect the full stroke position, and the position can be detected at high resolution within the range centred around the recommended mounting B dimension.

# D-MH2 Series

## 2. Actuator with long stroke

There will be a point where the process data crosses the peak/bottom and the same process data is output. By mounting the 2 in 1 auto switch at the recommended mounting dimension, position detection can be made within the “discriminable range,” which is defined as the range between the peak and the bottom of the process data.

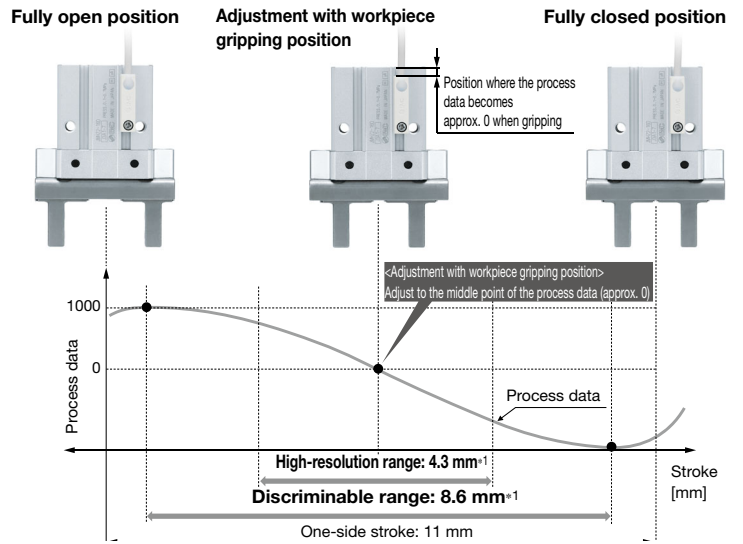
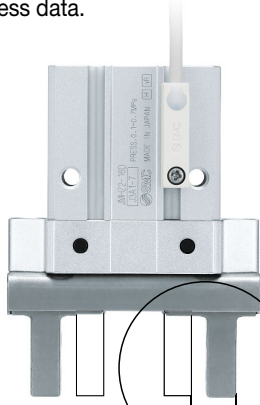

\*1 When mounted on an MHZ2 (Ø 32, round groove) air gripper

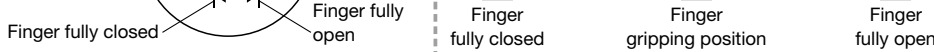

Series/Mounting	Bore size [mm]	Opening/Closing stroke [mm]	
		Both sides	One side
<b>JMHZ2</b>	16	10	5
	20	14	7
<b>MHZ2</b>	Round groove	25	14
		32	22
		40	30
	Square groove	25	14
		32	22
		40	30
<b>MHZL2</b>	Round groove	16	12
		20	18
		25	22
	Square groove	10	8
		16	12
		20	18
<b>MHF2 (D/D1/D2)</b>	8	32 (D2)	16 (D2)
	12	48 (D2)	24 (D2)
	16	64 (D2)	32 (D2)
	20	80 (D2)	40 (D2)
<b>MHZJ2</b>	25	14	7
	32	22	11
	40	30	15
<b>MHL2-Z (D/D1/D2)</b>	10	20 (D)	10 (D)
	16	30 (D)	15 (D)
	20	40 (D)	20 (D)
	25	50 (D)	25 (D)
	32	70 (D)	35 (D)
<b>MDHR2</b>	30	18	9
	40	25	12.5
<b>MHKL2</b>	12	11	5.5
	16	14	7
	25	22	11
<b>MHK2 Ø 25</b>	25	14	7
<b>MHS2/MHS4</b>	63	16	8
<b>MHS3</b>	63	16	8
	80	20	10
	100	24	12
	125	32	16

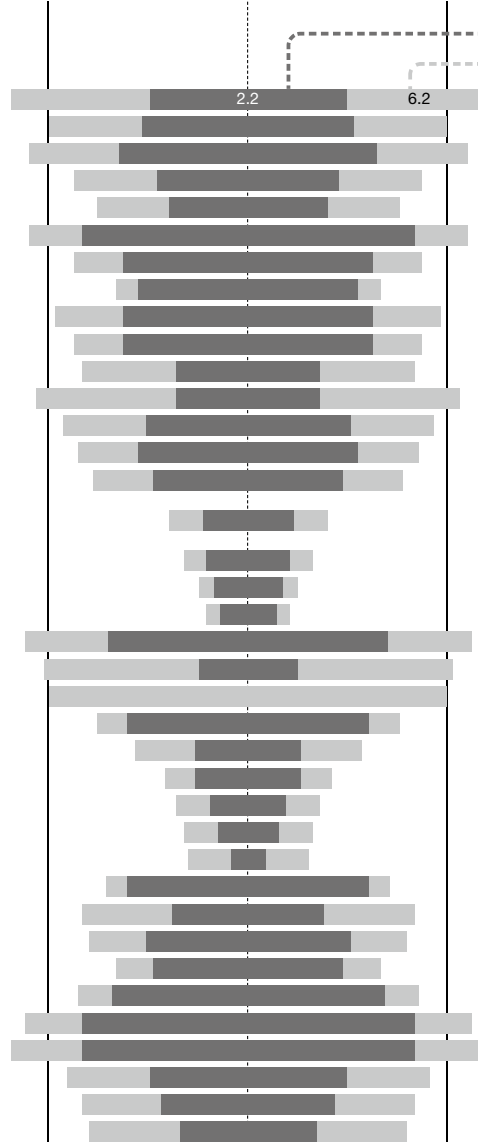

High-resolution range [mm]	Discriminable range [mm]	Note
2.2	6.2	
3.2	7.0	
4.2	7.9	
4.3	8.6	
4.9	8.8	
5.2	8.0	
5.7	8.3	
6.4	8.8	
3.1	5.7	
4.8	7.0	
4.2	7.9	
1.5	4.3	
3.2	5.4	
5.2	7.2	
5.2	8.0	
2.9	5.6	Excludes the short type
3.8	5.8	
3.5	5.7	
2.8	5.9	
4.2	7.9	
2.9	11.3	
—	15.3	
5.0	6.9	
3.9	6.7	
5.2	7.2	
4.5	7.1	
4.4	9.1	
2.8	12.1	
4.3	5.2	
1.8	4.3	
3.0	5.1	
4.0	5.8	
4.0	5.8	
6.4	9.0	
6.4	9.5	
6.0	9.1	
6.2	9.5	
6.3	11.7	

- \* All the above values are reference values.
- \* The discriminable range is the range between the peak and the bottom of the process data. (One side of the gripper)  
For details, refer to the operation manual of the product.
- \* There is a possibility of the above values fluctuating significantly depending on the ambient environment. Be sure to conduct a test operation in the actual operating environment.
- \* Refer to the operation manual for details on how to determine the mounting position of other switches.



# Applicable Actuators and 2 in 1 Auto Switch Mounting **D-MH2** Series

Fully open position    Adjustment with workpiece gripping position    Fully closed position

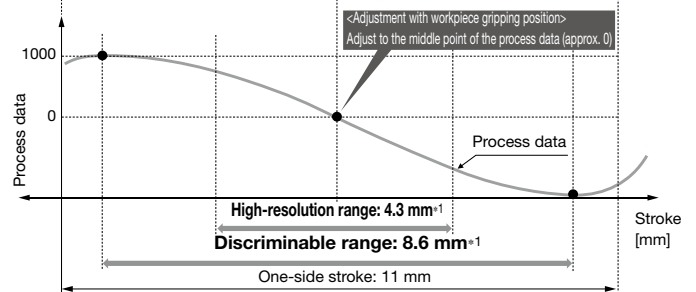
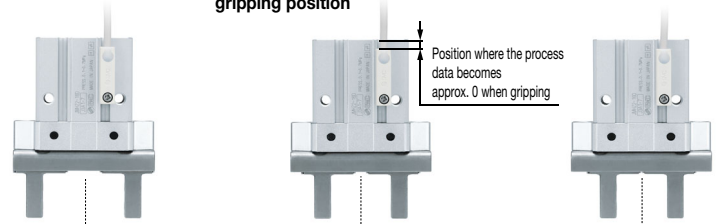

\*1 When mounted on an MHZ2 (Ø 32, round groove) air gripper

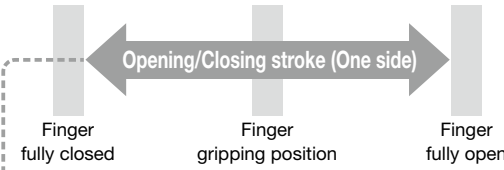
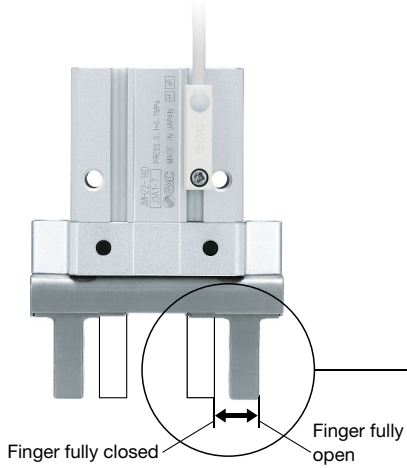

Series/Mounting	Bore size [mm]	Opening/Closing stroke [mm]	
		Both sides	One side
<b>JMHZ2</b>	16	10	5
	20	14	7
<b>MHSL3</b>	16	10	5
	20	10	5
	25	12	6
	32	16	8
	63	32	16
	80	40	20
	100	48	24
125	64	32	
<b>MHSJ3/MHSH3/MHSHJ3</b>	63	16	8
	80	20	10
<b>MHT2</b>	40	—	—
	50	—	—
<b>MHY2</b>	10	—	—
	16	—	—
	20	—	—
	25	—	—
<b>MHW2</b>	20	—	—
	25	—	—
	32	—	—
	40	—	—
	50	—	—

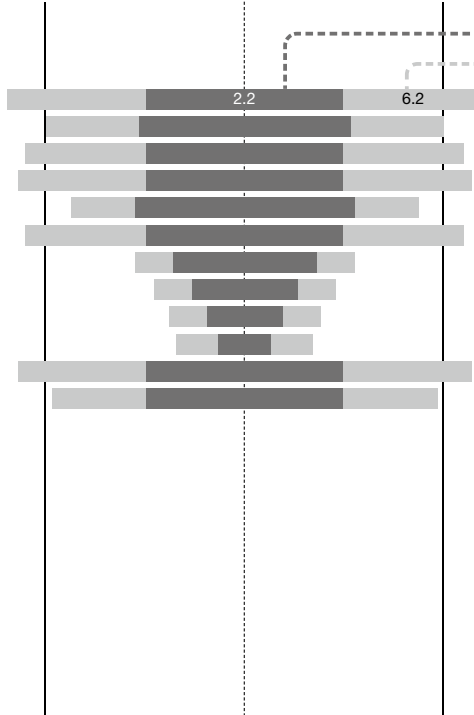

High-resolution range [mm]	Discriminable range [mm]	Note
2.2	6.2	
3.2	7.0	
2.7	5.6	
2.7	5.8	
3.5	4.9	
4.4	9.0	
6.4	9.5	
6.0	9.1	
6.2	9.5	
6.3	11.7	
4.6	9.4	
5.8	9.5	
Angle open/close type		

## Relationship between the stroke, the switch mounting position, and the process data

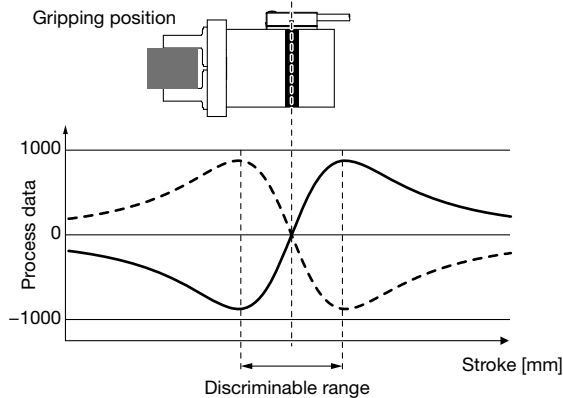

\* Refer to page 14 for details on the mounting method.



## D-MH2□ Series

# IO-Link Compatible 2 in 1 Auto Switch/Specific Product Precautions

Be sure to read this before handling the products. Refer to the back cover for safety instructions. For actuator and auto switch precautions, refer to the “Handling Precautions for SMC Products” and the “Operation Manual” on the SMC website: <https://www.smc.eu>

### Design / Selection

#### Caution

##### 1. The product cannot be used for length measurement.

A 2 in 1 auto switch outputs a magnetic field from the cylinder magnet as process data, and therefore the output is not linear to the cylinder stroke.

In addition, there are individual differences in the magnetic force of magnets. As such, the output values from magnets are different even if they are mounted to the same position on the same type actuator.

##### 2. The resolution and repeatability vary depending on the position relationship between the magnet and the sensor.

The resolution and repeatability decrease near the maximum or minimum peak of process data. Use them by mounting them to the recommended positions. If precision in repeatability is required, configure settings so that the process data at the output position will be close to 0 (in between peaks).

##### 3. Process data fluctuates due to the following factors.

Process data fluctuates in an environment which is affected by the ambient temperature, mounting orientation (terrestrial magnetism), wobbling (mechanical factor, supply pressure fluctuation, etc.), electrical noise disturbance, magnetic body (iron screw, iron powder, etc.), or a magnetic force. It is recommended to use non-magnetic materials for magnetic bodies, bolts, and so on in the surroundings.

When using the product for an application where the ambient temperature or mounting orientation changes greatly, it is recommended to set the ON point under conditions that are close to the actual operating environment and set a wider ON width or hysteresis.

##### 4. Take precautions when multiple cylinders or actuators are used close together.

When using two or more cylinders or actuators with a built-in magnet in close proximity to each other arranged in parallel, design so that they will maintain a separation distance of at least 40 mm.

(If the separation distance is specified for each of cylinder/actuator series, use that value.)

The accuracy of the 2 in 1 auto switch may be reduced and it may malfunction due to the magnetic field interference between them.

##### 5. The setup tool may not operate depending on the mobile battery it is connected to.

Connect this product to a 5 VDC mobile battery with an output current of 2 A or more. Depending on the mobile battery type, the setup tool may not operate. Be sure to confirm the mobile battery specifications. When used at a high temperature (above the operating temperature range), malfunction, fire, or burns may result. Therefore, be sure to follow the mobile battery usage instructions and precautions.

In addition, do not connect the product to any power supply other than a mobile battery. Doing so may prevent the product from operating or result in a power supply malfunction.

This product may not operate if connected to a mobile battery with a function that automatically turns the power supply OFF according to the mobile battery's current consumption. We recommend using a mobile battery that allows you to turn this function ON/OFF.

### Design / Selection

#### Caution

##### 6. Use a mobile battery that complies with the laws and regulations of each region and country.

We do not accept any responsibility for damages caused to our products or for losses caused due to the malfunction of our products from the use of an illegal mobile battery.

### Mounting / Adjustment

#### Caution

##### 1. Adjust the mounting position of the 2 in 1 auto switch after checking the actual operating conditions.

The full stroke may not be detected even for cylinders and actuators that can detect full strokes depending on the setting environment (magnetic bodies in the surroundings, temperature, etc.). In addition, the repeatability may deteriorate.

Confirm the operating conditions in the actual environment before use.

##### 2. Change setting of the 2 in 1 auto switch when power supply voltage is stable.

If setting is changed while power supply voltage is unstable, incorrect data may be written or setting may not be performed correctly.

### Maintenance

#### Warning

##### 1. The 2 in 1 auto switch may malfunction unexpectedly, making it impossible to confirm safety. Therefore, perform maintenance or inspection regularly.

### WEEE Directive

##### 1. This product is classified as a waste electrical or electronic equipment according to WEEE Directive 2012/19/EU. Therefore, in order to reduce the impact on human health and the environment, it should not be disposed of as municipal waste.

## Safety Instructions

These safety instructions are intended to prevent hazardous situations and/or equipment damage. These instructions indicate the level of potential hazard with the labels of “Caution,” “Warning” or “Danger.” They are all important notes for safety and must be followed in addition to International Standards (ISO/IEC)<sup>1)</sup>, and other safety regulations.

### Danger:

**Danger** indicates a hazard with a high level of risk which, if not avoided, will result in death or serious injury.

### Warning:

**Warning** indicates a hazard with a medium level of risk which, if not avoided, could result in death or serious injury.

### Caution:

**Caution** indicates a hazard with a low level of risk which, if not avoided, could result in minor or moderate injury.

- 1) ISO 4414: Pneumatic fluid power – General rules and safety requirements for systems and their components.
- ISO 4413: Hydraulic fluid power – General rules and safety requirements for systems and their components.
- IEC 60204-1: Safety of machinery – Electrical equipment of machines. (Part 1: General requirements)
- ISO 10218-1: Robots and robotic devices - Safety requirements for industrial robots - Part 1: Robots.
- etc.

## Warning

### 1. The compatibility of the product is the responsibility of the person who designs the equipment or decides its specifications.

Since the product specified here is used under various operating conditions, its compatibility with specific equipment must be decided by the person who designs the equipment or decides its specifications based on necessary analysis and test results. The expected performance and safety assurance of the equipment will be the responsibility of the person who has determined its compatibility with the product. This person should also continuously review all specifications of the product referring to its latest catalogue information, with a view to giving due consideration to any possibility of equipment failure when configuring the equipment.

### 2. Only personnel with appropriate training should operate machinery and equipment.

The product specified here may become unsafe if handled incorrectly. The assembly, operation and maintenance of machines or equipment including our products must be performed by an operator who is appropriately trained and experienced.

### 3. Do not service or attempt to remove product and machinery/equipment until safety is confirmed.

1. The inspection and maintenance of machinery/equipment should only be performed after measures to prevent falling or runaway of the driven objects have been confirmed.
2. When the product is to be removed, confirm that the safety measures as mentioned above are implemented and the power from any appropriate source is cut, and read and understand the specific product precautions of all relevant products carefully.
3. Before machinery/equipment is restarted, take measures to prevent unexpected operation and malfunction.

### 4. Our products cannot be used beyond their specifications. Our products are not developed, designed, and manufactured to be used under the following conditions or environments.

**Use under such conditions or environments is not covered.**

1. Conditions and environments outside of the given specifications, or use outdoors or in a place exposed to direct sunlight.
2. Use for nuclear power, railways, aviation, space equipment, ships, vehicles, military application, equipment affecting human life, body, and property, fuel equipment, entertainment equipment, emergency shut-off circuits, press clutches, brake circuits, safety equipment, etc., and use for applications that do not conform to standard specifications such as catalogues and operation manuals.
3. Use for interlock circuits, except for use with double interlock such as installing a mechanical protection function in case of failure. Please periodically inspect the product to confirm that the product is operating properly.

## Caution

**We develop, design, and manufacture our products to be used for automatic control equipment, and provide them for peaceful use in manufacturing industries.**

**Use in non-manufacturing industries is not covered.**

Products we manufacture and sell cannot be used for the purpose of transactions or certification specified in the Measurement Act.

The new Measurement Act prohibits use of any unit other than SI units in Japan.

## Limited warranty and Disclaimer/Compliance Requirements

The product used is subject to the following “Limited warranty and Disclaimer” and “Compliance Requirements”. Read and accept them before using the product.

### Limited warranty and Disclaimer

1. The warranty period of the product is 1 year in service or 1.5 years after the product is delivered, whichever is first.<sup>2)</sup> Also, the product may have specified durability, running distance or replacement parts. Please consult your nearest sales branch.
2. For any failure or damage reported within the warranty period which is clearly our responsibility, a replacement product or necessary parts will be provided. This limited warranty applies only to our product independently, and not to any other damage incurred due to the failure of the product.
3. Prior to using SMC products, please read and understand the warranty terms and disclaimers noted in the specified catalogue for the particular products.
- 2) Vacuum pads are excluded from this 1 year warranty.  
A vacuum pad is a consumable part, so it is warranted for a year after it is delivered. Also, even within the warranty period, the wear of a product due to the use of the vacuum pad or failure due to the deterioration of rubber material are not covered by the limited warranty.

### Compliance Requirements

1. The use of SMC products with production equipment for the manufacture of weapons of mass destruction (WMD) or any other weapon is strictly prohibited.
2. The exports of SMC products or technology from one country to another are governed by the relevant security laws and regulations of the countries involved in the transaction. Prior to the shipment of a SMC product to another country, assure that all local rules governing that export are known and followed.

## Safety Instructions

Be sure to read “Handling Precautions for SMC Products” (M-E03-3) before using.

## SMC Corporation (Europe)

<b>Austria</b>	+43 (0)2262622800	www.smc.at	office.at@smc.com
<b>Belgium</b>	+32 (0)33551464	www.smc.be	info@smc.be
<b>Bulgaria</b>	+359 (0)2807670	www.smc.bg	sales.bg@smc.com
<b>Croatia</b>	+385 (0)13707288	www.smc.hr	sales.hr@smc.com
<b>Czech Republic</b>	+420 541424611	www.smc.cz	office.at@smc.com
<b>Denmark</b>	+45 70252900	www.smc.dk.com	smc.dk@smc.com
<b>Estonia</b>	+372 651 0370	www.smcee.ee	info.ee@smc.com
<b>Finland</b>	+358 207513513	www.smc.fi	smc.fi@smc.com
<b>France</b>	+33 (0)164761000	www.smc-france.fr	supportclient.fr@smc.com
<b>Germany</b>	+49 (0)61034020	www.smc.de	info.de@smc.com
<b>Greece</b>	+30 210 2717265	www.smchellas.gr	sales@smchellas.gr
<b>Hungary</b>	+36 23513000	www.smc.hu	office.hu@smc.com
<b>Ireland</b>	+353 (0)14039000	www.smcautomation.ie	technical.ie@smc.com
<b>Italy</b>	+39 03990691	www.smcitalia.it	mailbox.it@smc.com
<b>Latvia</b>	+371 67817700	www.smc.lv	info.lv@smc.com

<b>Lithuania</b>	+370 5 2308118	www.smclt.lt	info.lt@smc.com
<b>Netherlands</b>	+31 (0)205318888	www.smc.nl	info@smc.nl
<b>Norway</b>	+47 67129020	www.smc-norge.no	post.no@smc.com
<b>Poland</b>	+48 22 344 40 00	www.smc.pl	office.pl@smc.com
<b>Portugal</b>	+351 214724500	www.smc.eu	apoiocliente.pt@smc.com
<b>Romania</b>	+40 213205111	www.smcromania.ro	office.ro@smc.com
<b>Russia</b>	+7 (812)3036600	www.smc.eu	sales@smcru.com
<b>Slovakia</b>	+421 (0)413213212	www.smc.sk	sales.sk@smc.com
<b>Slovenia</b>	+386 (0)73885412	www.smc.si	office.si@smc.com
<b>Spain</b>	+34 945184100	www.smc.eu	post.es@smc.com
<b>Sweden</b>	+46 (0)86031240	www.smc.nu	order.se@smc.com
<b>Switzerland</b>	+41 (0)523963131	www.smc.ch	helpcentre.ch@smc.com
<b>Turkey</b>	+90 212 489 0 440	www.smcturkey.com.tr	satis.tr@smc.com
<b>UK</b>	+44 (0)845 121 5122	www.smc.uk	sales.gb@smc.com
<b>South Africa</b>	+27 10 900 1233	www.smcza.co.za	Sales.za@smc.com