

Auto Feed Lube, Auto Feed Tank

ALF400 to 900, ALT-5/-9

Standard Specifications

Model	Auto feed lube						Auto feed tank			
	ALF400	ALF400-06	ALF500	ALF600	ALF800	ALF900	ALT-5	ALT-5-IS- ¹ / ₂	ALT-9	ALT-9-IS- ¹ / ₂
Port size	1/4 3/8 1/2	3/4	3/4 1	1	1 1/4 1 1/2	2	AIR: 1/4 OIL: 3/8			
Fluid	Air									
Proof pressure	1.5 MPa									
Max. operating pressure	0.7 MPa						1.0 MPa			
Operating pressure differential range (Note 1) (Difference between tank pressure and line pressure)	0.1 to 0.6 MPa						—			
Vibration resistance (Pressure differential 0.3 MPa)	1 G (9.81 m/sec ²) or less									
Min. operating flow (L/min (ANR)) (Note 2)	1/4: 65 3/8: 100 1/2: 120	120	190	220	1 1/4: 460 1 1/2: 650	1800	—			
Bowl capacity (cm ³) (Note 3) (Capacity between levels)	—						5000 (4400)	5000 (3400)	9000 (7800)	9000 (6000)
Recommended lubricant	Turbine oil Class 1 (With no additives), ISO VG32									
Ambient and fluid temperature	-5 to 60°C (No freezing)									
Bowl material	Polycarbonate						Metal (Steel tubing for machine construction)			
Weight (kg)	0.85	0.88	1	1.15	1.85	1.9	12.6	13.2	26.0	26.6
Accessory (Standard) Bowl guard	●	●	●	●	●	●	—			

Note 1) Tank pressure is the pressure of Auto Feed Tank and line pressure is the pressure of Auto Feed Lube.

Note 2) Conditions: Inlet pressure 0.5 MPa, 5 drops/min, Turbine oil class 1 (with no additives) ISO VG32, Temperature 20°C, Needle fully open. Use air consumption rate for minimum operating flow.

Note 3) Capacity between levels: in the case of float switch equipped model, the capacity is measured in levels between the level gauge upper limit and the lower limit of the float switch detective range.

The problem of running out of oil is prevented because the oil is fed automatically. This system makes lubrication work unnecessary, thus significantly reducing the amount of maintenance labour.



ALF400



ALT-5

Accessories (Options) Part No.

Description	Part No.					
	ALF400	ALF400-06	ALF500	ALF600	ALF800	ALF900
Bracket	B44P	B44-1P	1 1/4: B45-1P 1 1/2: B45-2P	B46P	—	—

Note) A float switch can not be mounted on "ALT-5" or "ALT-9" afterwards.

Symbol

Auto feed lube



Auto feed tank



Piping example

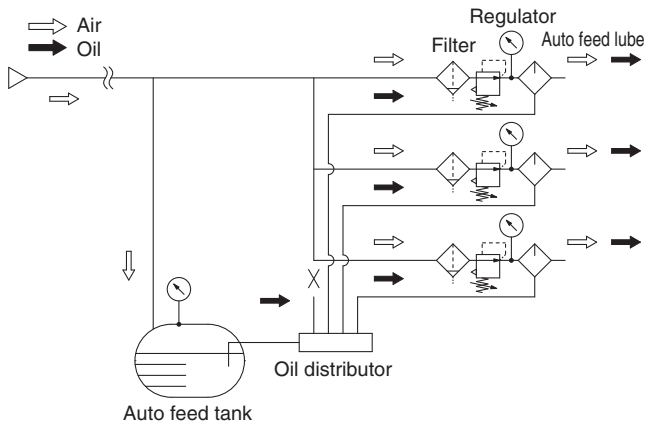

ALF400 to 900

How to Order

<Auto Feed Lube>

ALF 40 0 - 02 - - -

Auto Feed Lube

Body size

40	1 1/2
50	3/4
60	1
80	1 1/2
90	2

Port size

02	1/4
03	3/8
04	1/2
06	3/4
10	1
12	1 1/4
14	1 1/2
20	2

Thread type

-	Rc
N	NPT
F	G

Made to Order

-	None
X208	Metal case with a level gauge

Option

-	-
R	Flow direction: Right to left

Option

Symbol	Description	Applicable model
-	-	-
B	With bracket	ALF400 to 600

Operating Pressure Range

Tank and line pressure

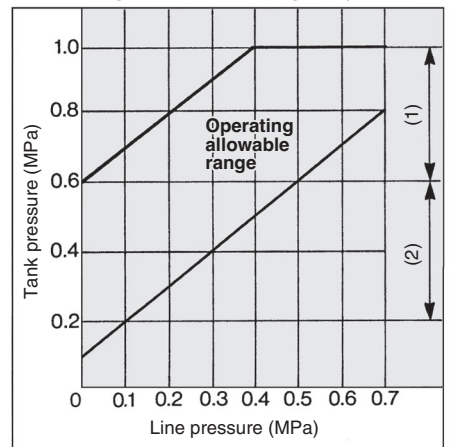

- Note 1) Tank pressure is removed when line pressure is stopped.
 Note 2) Tank pressure is kept same when line pressure is stopped possible to use.

<Auto Feed Tank>

ALT - 5 - IS-1 -

Auto Feed Tank

Thread Type

-	Rc
N	NPT
E	G

Tank capacity

5	5000 cm ³ tank
9	9000 cm ³ tank

Option

-	-
R	Flow direction: Left to right

Option

IS-1	W/float switch (Bottom limit ON)
IS-2	W/float switch (Bottom limit OFF)



⚠ Precautions

Be sure to read this before handling the products. Refer to page 9 for safety instructions and pages 13 to 17 for precautions on every series.

Mounting

⚠ Warning

If the pressure is discharged, the oil could flow back if the operating pressure differential range (the differential between the tank and line pressures) exceeds 0.6 MPa. Therefore, make sure to also discharge the tank pressure.

⚠ Caution

Install the float vertically inside the bowl so that it will not come into contact with the siphon tube, preventing the oil from dripping poorly.

Maintenance

⚠ Caution

Oil cannot be fed into Auto Feed Lube under being pressurized. We recommend oil is supplied from cam handle (plug for oil supply) of an auto feed tank.

Working Principle/Auto Feed Lube

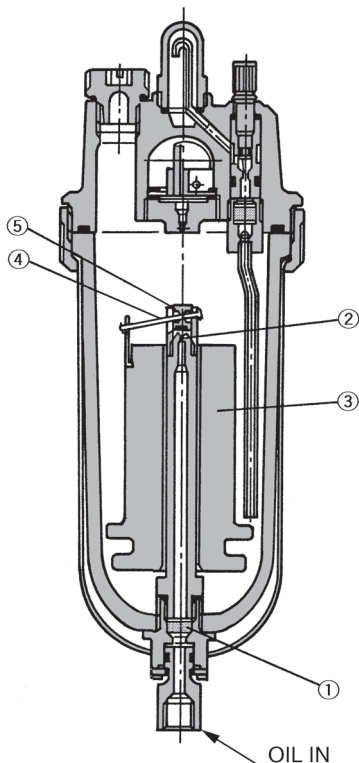

The oil that has been pumped from the tank passes through felt (1) where it is filtered, and is fed into the case through nozzle (2). When the volume of oil reaches a certain level, float (3) ascends, valve (5) descends via lever (4), nozzle (2) closes, and the feeding of oil stops, thus completing the oil feeding process. When the oil inside the case is consumed, float (3) descends, valve (5) ascends via lever (4), allowing oil to be fed from nozzle (2).

Construction: Auto Feed Lube

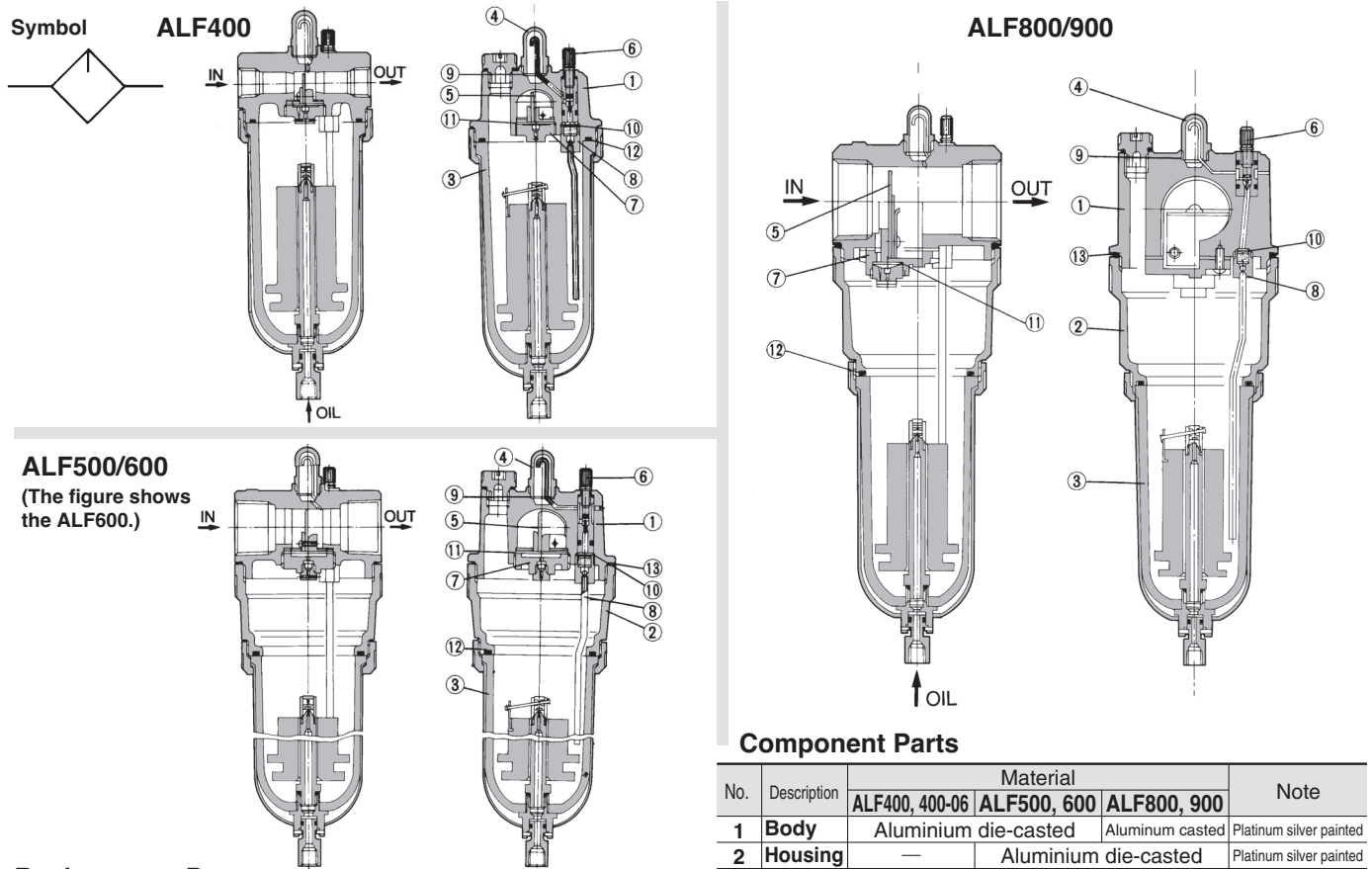

Replacement Parts

No.	Description	Material	Part no.						Qty.
			ALF400	ALF400-06	ALF500	ALF600	ALF800	ALF900	
3	Auto feed Standard X208	—	ALF-3	ALF-3	ALF-3	ALF-3	ALF-3	ALF-3	1
			ALF-3-X208	ALF-3-X208	ALF-3-X208	ALF-3-X208	ALF-3-X208	ALF-3-X208	
			ALF-3-X208	ALF-3-X208	ALF-3-X208	ALF-3-X208	ALF-3-X208	ALF-3-X208	
4	Sight dome	Polycarbonate	12316	12316	12316	12316	12316	12316	1
5	Bumper assembly	—	123122-3A (04) 123122-2A (03) 123122-1A (02)	123122-3A	123210A	123310A	123417A (12) 123416A (14)	12356A	1
6	Needle stud assembly	—	123128PA	123128PA	123128PA	123128PA	123128PA	123128PA	1
7	Retainer assembly	—	123182 ^{Note1)}	123182 ^{Note1)}	12325 ^{Note2)}	12335A-1	123032 ^{Note1)}	—	1
8	Siphon tube assembly	—	124230A	124230A	124231A	124232A	124232A	124232A	1
9	Sight dome seal	Urethane rubber	12318	12318	12318	12318	12318	12318	1
10	Siphon nut seal	Urethane rubber	123111	123111	123111	123111	123111	123111	1
11	Bumper retainer seal	NBR	123126	123126	123213	123313	123011	—	2 (1) ^{Note3)}
12	Bowl O-ring	NBR	113136	113136	113136	113136	113136	113136	1
13	Housing O-ring	NBR	—	—	KA00465	KA00466	KA00466	KA00466	1

Note 1) Description: Bumper retainer, Material: POM Note 2) Description: Bumper retainer, Material: Aluminium alloy

Note 3) (): Qty. for ALF800 only

Construction: Auto Feed Tank

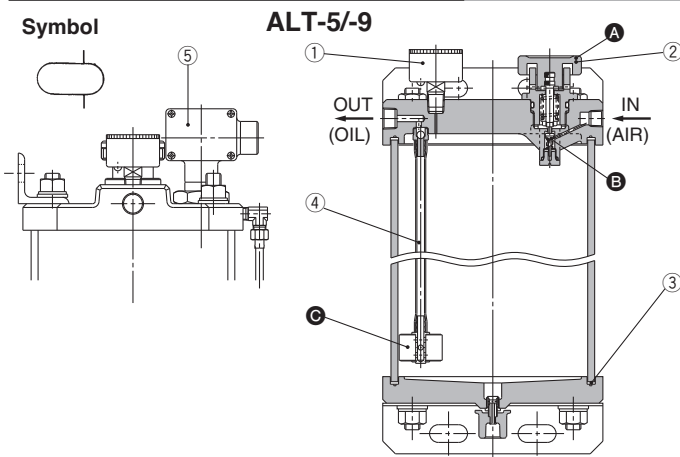

Working principle/Auto Feed Tank

By turning cam handle (A) 90° clockwise, valve (B) opens, allowing the air that has entered from the IN side to be introduced into the tank. Due to the air pressure, the oil in the tank passes through felt (C) and exits from the OUT side. Turning cam handle (A) 90° counterclockwise stops the feeding of the oil.

Component Parts

No.	Description	Material	Part no.		Qty.
			(N, E) ALT-5	(N, E) ALT-5-IS-1, 2 (N, E) ALT-9 (N, E) ALT-9-IS-1, 2	
1	Pressure gauge	—	G46-10-02(Nil, E) G46-P10-N02-X03(N)		1
2	Cam handle assembly	—	12374AP		1
3	Seal	NBR	12377	12384	2
4	Siphon tube assembly	—	123712A		1
5	Float switch	—	IS410-1, 2	—	IS410-1, 2

* IS410-1: Bottom limit ON
IS410-2: Bottom limit OFF

ALF400 to 900

Dimensions: Auto Feed Lube

ALF400

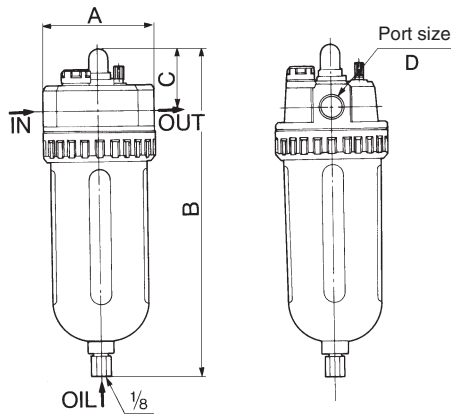

ALF800/900

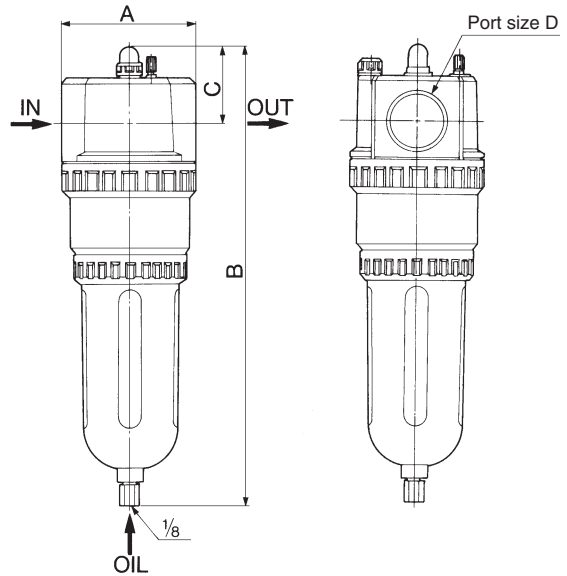

ALF500/600

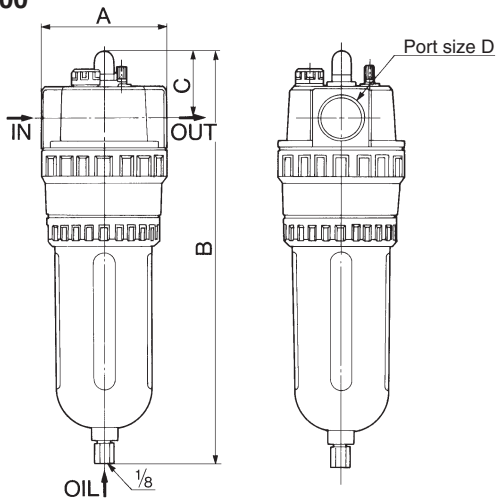

Model	Port size D	A	B	C
ALF400	1/4, 3/8, 1/2	80	239	44
ALF400-06	3/4	85	247	46
ALF500	3/4, 1	90	296	48
ALF600	1	100	320	51
ALF800	1 1/4, 1 1/2	100	339	59
ALF900	2	100	345	63

Dimensions: Auto Feed Tank

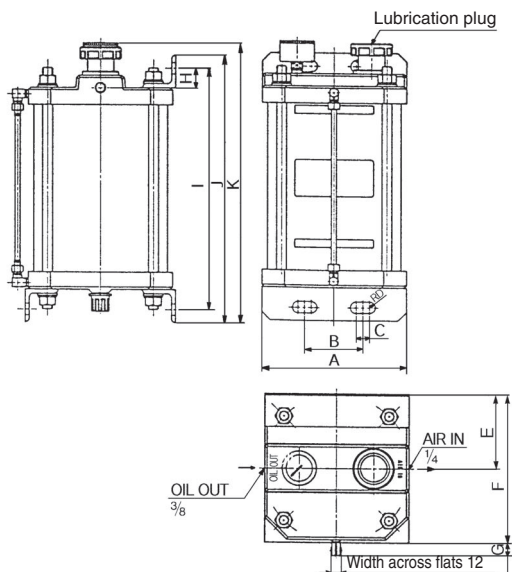

Float switch

Contact point capacity: AC: 15 VA, DC: 15 W
Contact point construction: 1a, 1b

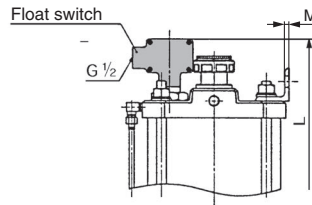

Model	A	B	C	D	E	F	G	H	I	J	K	L	M
ALT-5	174	70	16	7	91	182	15	24	382	414	428	—	5
ALT-5-IS	174	70	16	7	91	182	15	24	382	414	428	449	5
ALT-9	234	108	30	7	121	242	16	40	422	472	—	—	5
ALT-9-IS	234	108	30	7	121	242	16	40	422	472	—	482	5

Dimensions

Oil tank: ALT10

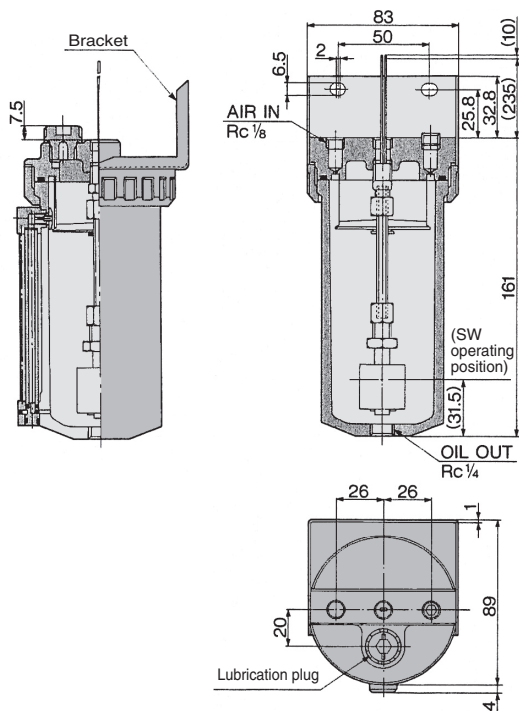

Oil tank: ALT20

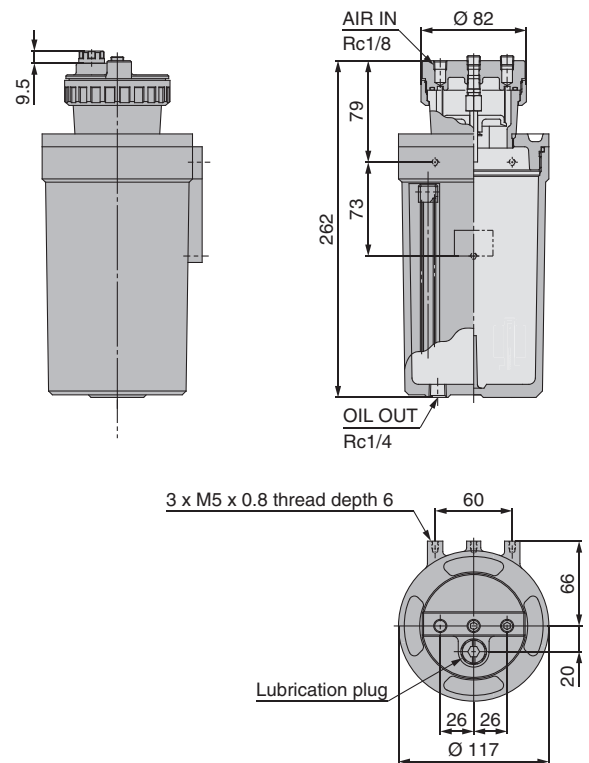

Handling Precautions

Mounting

1. Mount the air pipes after sufficiently flushing them.
2. When screwing in pipes or fittings, be careful to avoid letting cutting chips from pipe screws, sealant, etc. get mixed in. When winding with sealant tape, be sure to leave 1.5 to 2 threads remaining unwrapped.

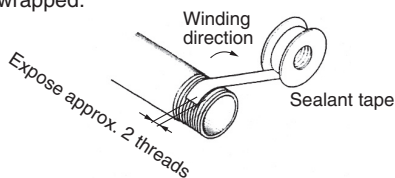

3. To screw a piping material into a component, tighten it by hand while holding the female thread side, and then tighten it two or three turns with an appropriate tool. For a tightening torque guide, refer to the table on the right. Excessive tightening may damage the threads or internal parts, and insufficient tightening may cause seal failure or loosen the threads. Furthermore, tightening without holding the female thread side can cause damage due to the excessive force that is applied directly to the bracket.

Recommended tightening torque (N·m)

Connecting thread size	1/8	1/4
Recommended tightening torque	3 to 5	8 to 12

- Additionally, the screw-in depth of the fitting to the oil outlet should be 6 mm or less. If the fitting is screwed in 6 mm or more, the internal parts may be broken, causing malfunction.
4. When using the oil tank while exposing it to the outside air, mount it in a higher position than the impulse lubricator.
 5. Provide enough space above the air release knob of the impulse lubricator to release the air.
 6. For ALT10 series, a slight clearance is provided between the product and bracket. If this clearance is not allowable, contact SMC.

Lubrication

1. After supplying oil to the oil tank, a large volume of air bubbles will be mixed in with the oil, so either wait for the air bubbles to dissipate, or use vacuum suction to remove the bubbles before using the equipment.
2. If air enters the interior of the impulse lubricator pump chamber, oil will cease to be discharged; if this happens, be sure to release the air.
3. Never screw any plug, etc. into the OIL OUT side of the impulse lubricator.

ALF400 to 900, ALT-5/-9 Related Products:

Oil Distributor VA, VB Series

How to Order

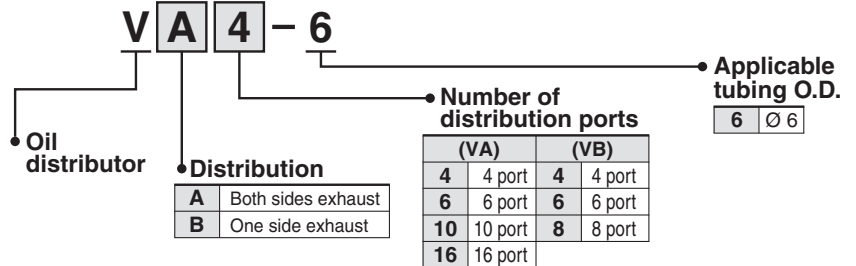
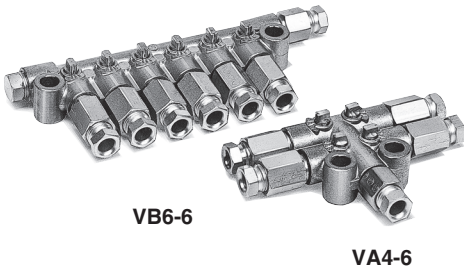

Dimensions

VA □ -6

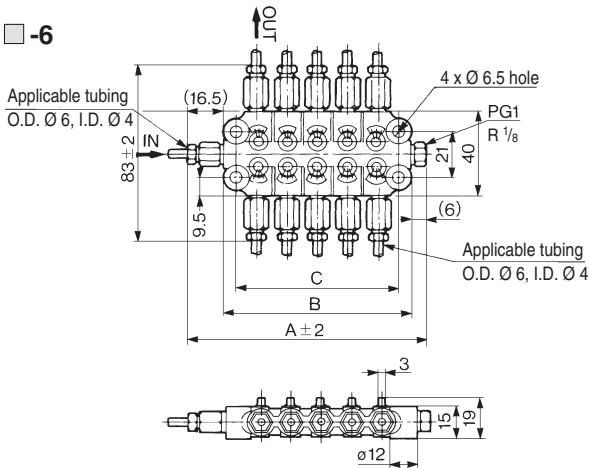

Model	Number of distribution ports	A	B	C	Applicable tubing
VA4-6	4	—	36.5	—	Ø 6
VA6-6	6	82.5	60	48	
VA10-6	10	110.5	88	76	
VA16-6	16	152.5	130	118	

Note) Insert seal plug (PG1) into the distribution port which is not used.

VB □ -6

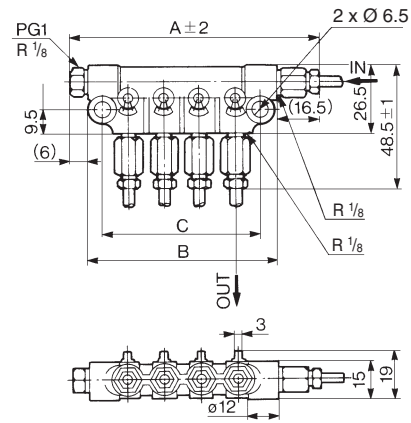

Model	Number of distribution ports	A	B	C	Applicable tubing
VB4-6	4	96.5	74	62	Ø 6
VB6-6	6	124.5	102	90	
VB8-6	8	152.5	130	118	

Nylon Tubing



Specifications

Model	T0604
Max. operating pressure	1.5 MPa
Burst pressure	Refer to the burst pressure characteristics curve.
Min. bending radius (mm) ^{Note)}	24
Operating temperature	-20 °C to 60 °C
Material	Nylon 12

Note) The value at temp. of 20 °C and with O.D. variable rate 10 % max.

How to Order

T 0604 B - 20

Nylon tubing	Colour		Length per roll
	Symbol	Colour	
Tube size O.D. Ø 6 I.D. Ø 4	B	Black	20 20 m
	W	White	100 100 m roll (Black, white only)
	R	Red	
	BU	Blue	
	Y	Yellow	
	G	Green	

Burst Pressure Characteristics Curve and Operating Pressure

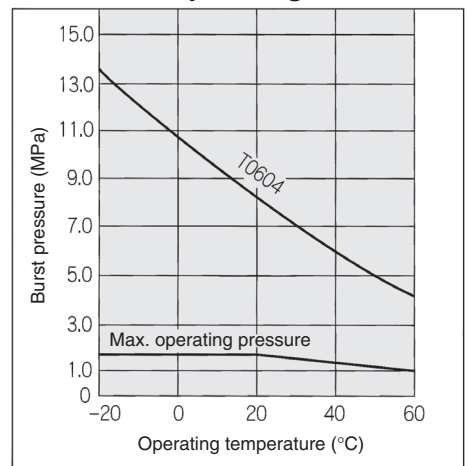

* Maximum operating pressure is 1/3 max. of burst pressure at 60 °C, considering the safety ratio.

Safety Instructions

These safety instructions are intended to prevent hazardous situations and/or equipment damage. These instructions indicate the level of potential hazard with the labels of “Caution,” “Warning” or “Danger.” They are all important notes for safety and must be followed in addition to International Standards (ISO/IEC) ¹⁾, and other safety regulations.

Danger:

Danger indicates a hazard with a high level of risk which, if not avoided, will result in death or serious injury.

Warning:

Warning indicates a hazard with a medium level of risk which, if not avoided, could result in death or serious injury.

Caution:

Caution indicates a hazard with a low level of risk which, if not avoided, could result in minor or moderate injury.

- 1) ISO 4414: Pneumatic fluid power – General rules and safety requirements for systems and their components.
- ISO 4413: Hydraulic fluid power – General rules and safety requirements for systems and their components.
- IEC 60204-1: Safety of machinery – Electrical equipment of machines. (Part 1: General requirements)
- ISO 10218-1: Robots and robotic devices - Safety requirements for industrial robots - Part 1: Robots.
- etc.

Warning

1. The compatibility of the product is the responsibility of the person who designs the equipment or decides its specifications.

Since the product specified here is used under various operating conditions, its compatibility with specific equipment must be decided by the person who designs the equipment or decides its specifications based on necessary analysis and test results. The expected performance and safety assurance of the equipment will be the responsibility of the person who has determined its compatibility with the product. This person should also continuously review all specifications of the product referring to its latest catalogue information, with a view to giving due consideration to any possibility of equipment failure when configuring the equipment.

2. Only personnel with appropriate training should operate machinery and equipment.

The product specified here may become unsafe if handled incorrectly. The assembly, operation and maintenance of machines or equipment including our products must be performed by an operator who is appropriately trained and experienced.

3. Do not service or attempt to remove product and machinery/equipment until safety is confirmed.

1. The inspection and maintenance of machinery/equipment should only be performed after measures to prevent falling or runaway of the driven objects have been confirmed.
2. When the product is to be removed, confirm that the safety measures as mentioned above are implemented and the power from any appropriate source is cut, and read and understand the specific product precautions of all relevant products carefully.
3. Before machinery/equipment is restarted, take measures to prevent unexpected operation and malfunction.

4. Our products cannot be used beyond their specifications. Our products are not developed, designed, and manufactured to be used under the following conditions or environments.

Use under such conditions or environments is not covered.

1. Conditions and environments outside of the given specifications, or use outdoors or in a place exposed to direct sunlight.
2. Use for nuclear power, railways, aviation, space equipment, ships, vehicles, military application, equipment affecting human life, body, and property, fuel equipment, entertainment equipment, emergency shut-off circuits, press clutches, brake circuits, safety equipment, etc., and use for applications that do not conform to standard specifications such as catalogues and operation manuals.
3. Use for interlock circuits, except for use with double interlock such as installing a mechanical protection function in case of failure. Please periodically inspect the product to confirm that the product is operating properly.

Caution

We develop, design, and manufacture our products to be used for automatic control equipment, and provide them for peaceful use in manufacturing industries.

Use in non-manufacturing industries is not covered.

Products we manufacture and sell cannot be used for the purpose of transactions or certification specified in the Measurement Act.

The new Measurement Act prohibits use of any unit other than SI units in Japan.

Limited warranty and Disclaimer/Compliance Requirements

The product used is subject to the following “Limited warranty and Disclaimer” and “Compliance Requirements”. Read and accept them before using the product.

Limited warranty and Disclaimer

1. The warranty period of the product is 1 year in service or 1.5 years after the product is delivered, whichever is first. ²⁾ Also, the product may have specified durability, running distance or replacement parts. Please consult your nearest sales branch.
2. For any failure or damage reported within the warranty period which is clearly our responsibility, a replacement product or necessary parts will be provided. This limited warranty applies only to our product independently, and not to any other damage incurred due to the failure of the product.
3. Prior to using SMC products, please read and understand the warranty terms and disclaimers noted in the specified catalogue for the particular products.
- 2) Vacuum pads are excluded from this 1 year warranty. A vacuum pad is a consumable part, so it is warranted for a year after it is delivered. Also, even within the warranty period, the wear of a product due to the use of the vacuum pad or failure due to the deterioration of rubber material are not covered by the limited warranty.

Compliance Requirements

1. The use of SMC products with production equipment for the manufacture of weapons of mass destruction (WMD) or any other weapon is strictly prohibited.
2. The exports of SMC products or technology from one country to another are governed by the relevant security laws and regulations of the countries involved in the transaction. Prior to the shipment of a SMC product to another country, assure that all local rules governing that export are known and followed.

Safety Instructions

Be sure to read “Handling Precautions for SMC Products” (M-E03-3) before using.

SMC Corporation (Europe)

Austria	+43 (0)2262622800	www.smc.at	office@smc.at
Belgium	+32 (0)33551464	www.smc.be	info@smc.be
Bulgaria	+359 (0)2807670	www.smc.bg	office@smc.bg
Croatia	+385 (0)13707288	www.smc.hr	office@smc.hr
Czech Republic	+420 541424611	www.smc.cz	office@smc.cz
Denmark	+45 70252900	www.smc.dk.com	smc@smc.dk.com
Estonia	+372 651 0370	www.smcee.ee	info@smcee.ee
Finland	+358 207513513	www.smc.fi	smc.fi@smc.fi
France	+33 (0)164761000	www.smc-france.fr	supportclient@smc-france.fr
Germany	+49 (0)61034020	www.smc.de	info@smc.de
Greece	+30 210 2717265	www.smchellas.gr	sales@smchellas.gr
Hungary	+36 23513000	www.smc.hu	office@smc.hu
Ireland	+353 (0)14039000	www.smcautomation.ie	sales@smcautomation.ie
Italy	+39 03990691	www.smcitalia.it	mailbox@smcitalia.it
Latvia	+371 67817700	www.smc.lv	info@smc.lv

Lithuania	+370 5 2308118	www.smclt.lt	info@smclt.lt
Netherlands	+31 (0)205318888	www.smc.nl	info@smc.nl
Norway	+47 67129020	www.smc-norge.no	post@smc-norge.no
Poland	+48 222119600	www.smc.pl	sales@smc.pl
Portugal	+351 214724500	www.smc.eu	apoioclientept@smc.smces.es
Romania	+40 213205111	www.smcromania.ro	smcromania@smcromania.ro
Russia	+7 (812)3036600	www.smc.eu	sales@smcru.com
Slovakia	+421 (0)413213212	www.smc.sk	office@smc.sk
Slovenia	+386 (0)73885412	www.smc.si	office@smc.si
Spain	+34 945184100	www.smc.eu	post@smc.smces.es
Sweden	+46 (0)86031240	www.smc.nu	smc@smc.nu
Switzerland	+41 (0)523963131	www.smc.ch	info@smc.ch
Turkey	+90 212 489 0 440	www.smcturkey.com.tr	info@smcturkey.com.tr
UK	+44 (0)845 121 5122	www.smc.uk	sales@smc.uk

South Africa +27 10 900 1233 www.smcza.co.za zasales@smcza.co.za